

\$7.50

ALSO CSV-30
30 SELECT

Polyvend SuperSeller 3000

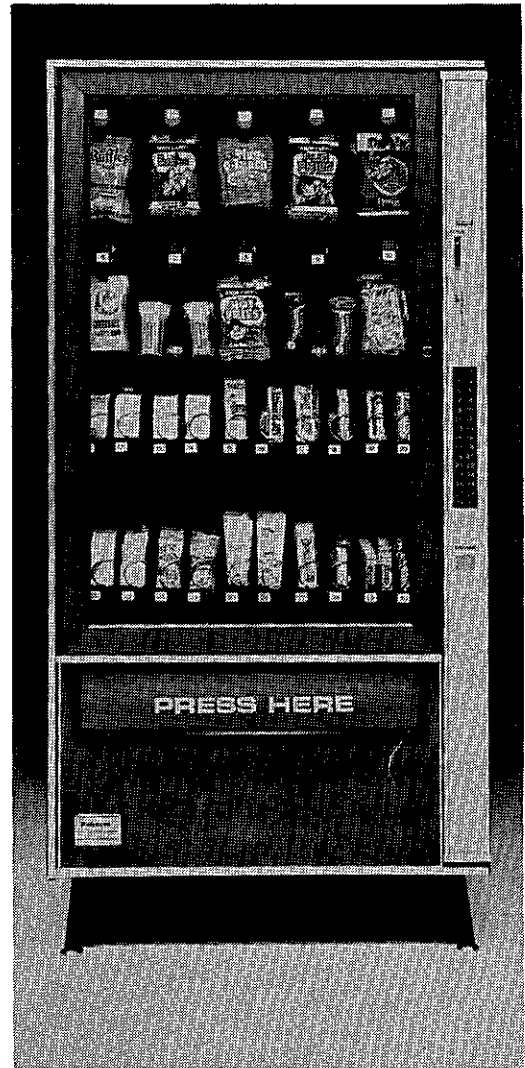
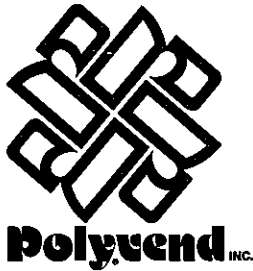

SERVICE MANUAL

SERVICE MANUAL 30 SELECT AUTOMATIC RACK MERCHANDISER

GENERAL

This merchandiser has been developed by Polyvend to offer large capacity and number of selections. A versatile combination is utilized - made up of wedge chain modules, candy cup dispensers and various sizes of helix trays. The number of selections (up to 30) and maximum capacity will vary, depending on the final configuration of modules, as determined by the type product to be vended. The possible variations of module configurations are described later in this manual.

Each dispensing unit is readily removable from the front for replacement or repair. The individual dispense motors are a DC type with a slip clutch arrangement for lock-up prevention.

Two versions of pricing capability are available from Polyvend - multi-price or four price. The multi-price uses the CoinCo M-150 mechanism and can accommodate as many different prices as there are selections. The four price version can have four different vend prices with no restriction by position and will operate with any 24 volt, 4 price coin mechanism. Since the electrical systems for these two pricing versions are different, the one needed should be specified when ordered from the factory.

The color and trim of the cabinet are optional and may be ordered to match other equipment and decor.

SPECIFICATIONS

OVERALL DIMENSIONS:

Height	72"
Width	36"
Depth	31½"
Front Clearance (Door)	31"

WEIGHT:

Shipping	600 lbs.
----------------	----------

ELECTRICAL:

Primary	115 VAC 2 AMP
Secondary	24 VAC 3.2 AMP

NOTE: Polyvend, Inc. will not be responsible for faulty or overloaded circuits where Polyvend machines are installed. The exact load imposed on each machine is stated in the related service manual. The sum of all machines installed in any one location will determine the total line load.



INSTALLATION

- Remove outside shipping carton.
- Inspect for damage resulting from improper handling and, if evident, file claim immediately with the carrier.
- Place machine into position and adjust leveling legs so it is level and aligned with adjacent machines.
- Locate small envelope in delivery compartment inside “Push” door and remove keys.
- Open glass service door with supplied key and remove all internal packing. (There are different numbered keys in envelope - one for product door, one for the back door, and, if so ordered, one for coin bank lock.)
- Remove price stickers from envelope shipped in delivery compartment and select the appropriate ones to match desired pricing of products.
- Peel off the adhesive backing and place selected price stickers on their perspective modules:
- Or, wedge and candy cup modules with the plastic number tab, place the price sticker just above the number.
- On the helix tray, place the price sticker on the front of the tray, just to the right of the number.
- Set vend prices:
 - Multi-Price:
 - Locate the large price select board behind sliding door on right inside of cabinet (FIGURE 1).
 - Refer to FIGURE 2 and note the number sequence from bottom to top along the back side of the large price select board. These correspond to the numbered position of each module. You will note there are two switch levers - one white and one black in each switch block. Each horizontal (front to back) row of the same colored switches control the price setting for that corresponding numbered position. (#1 to the bottom row of black levers.)
 - Also note the 5 price designations (5¢, 10¢, 20¢, 40¢, 80¢) along the top of the board. These correspond to the value of each vertical (top to bottom) column of switches.
 - The switch levers are either to the front or to the back. Toward the back (or left when facing the board) is the “off” position and toward the front is “on”. When “on” the value is accumulative with all other switches “on” in the row and the sum total is the price setting for that selection.
 - Set each selection (horizontal row) to the desired price setting.
 - Four Price:
 - Locate the four price terminal board behind sliding door to changer and the black numbered wires connected to that board.
 - Noting the position numbers of all modules to have the same price setting, reconnect all like ones to one of the four terminal strips on the board.
 - The 1 to 4 numbered designation on the terminal board strips correspond to the 1 to 4 price channels of the changer.
 - In coin equipment, set desired prices in accordance with changer instructions to correspond to the connections made to the terminal board above.
 - To insure proper operation of the coin mechanism, set a price on each of the 4 price levels even though one or more may not be used.

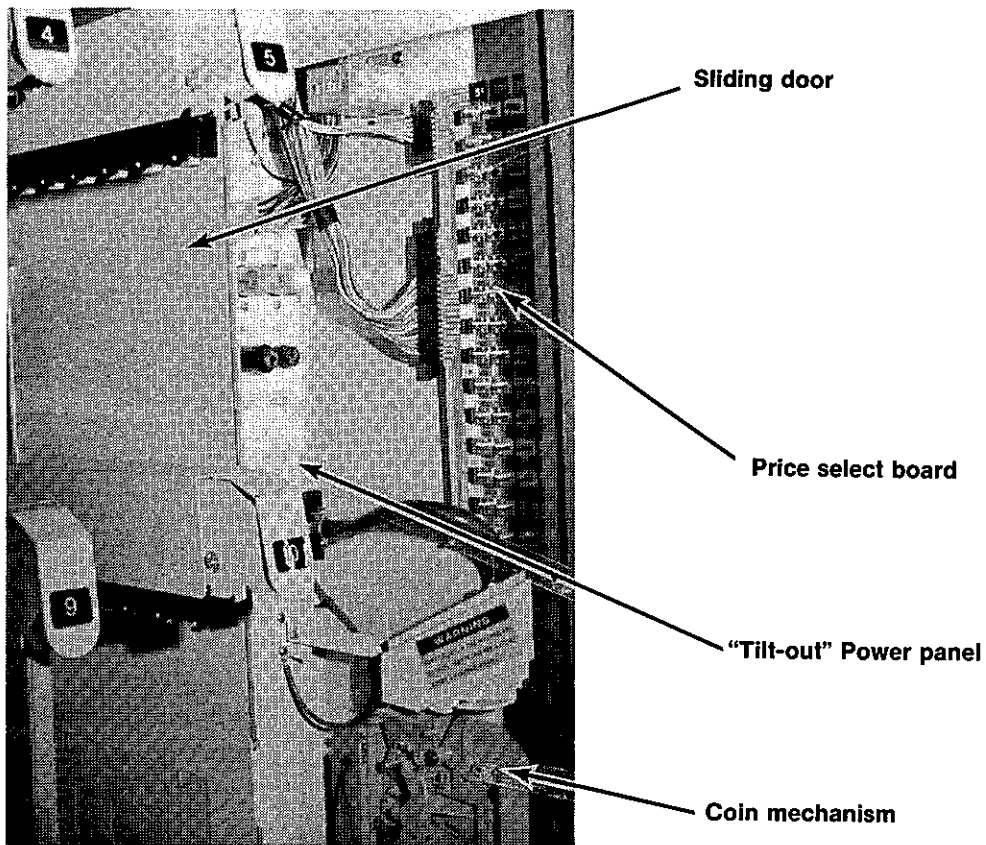
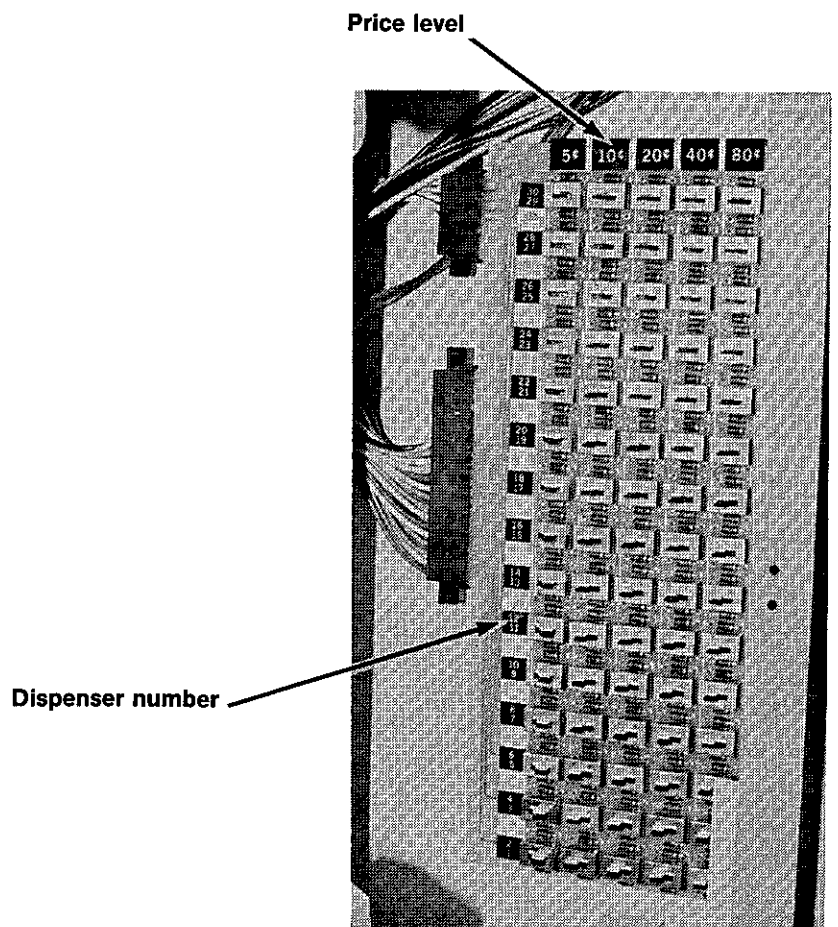

Fig. 1

Fig. 2
PRICE SELECTION BOARD



- Save extra fuses, etc. found in the envelopes.
- Plug the service cord into a 115 VAC source using the grounded, three pronged connector provided. If a suitably grounded outlet is not available, use a proper external ground on all locations.
- Load the coin tubes in the coin changer. (See changer instructions.)
- Load the machine with product.
NOTE: SEE PRODUCT LOADING SECTION OF THIS MANUAL TO PREVENT DAMAGE TO MODULES.
- Test operation of each dispensing module with coins.

PRODUCT LOADING

All loading is accomplished from the front. Using one of the keys provided, open the glass product door. There are three types of dispensers.

WEDGE (BAG) DISPENSER:

WARNING: DO NOT ATTEMPT TO PULL PRODUCT FROM THE BAG DISPENSER AT ANY TIME. SUCH ACTION WILL EITHER JAM THE MECHANISM OR PULL THE ASSEMBLIES APART.

To load, release the latch on each dispenser as shown in FIGURE 3 and pull forward until the slide hits the stop. Each bag is now inserted into a wedge assembly. The best way is to insert the bag at an angle and slide it in wedge to center (FIGURE 4A & B). Repeat on each wedge until positions from front to back are loaded. (NOTE: DO NOT LOAD LAST POSITION.)

To remove bag product, press upward on white lifter directly behind top of bag (FIGURE 4C).

Fig. 3

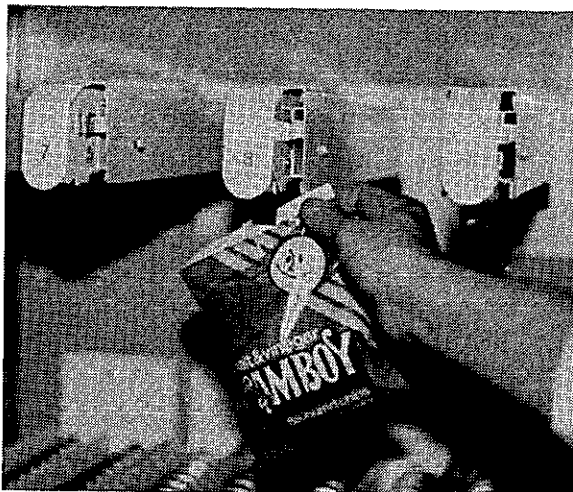
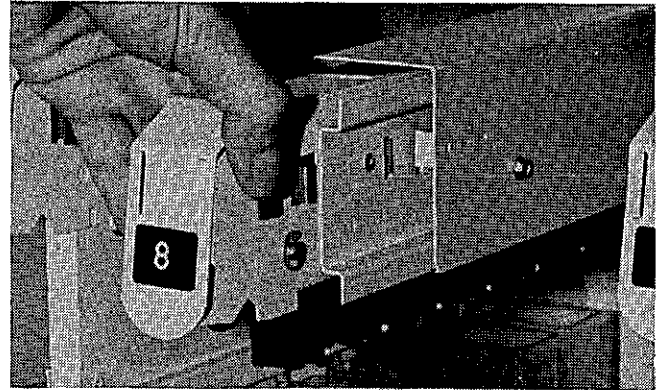

Fig. 4 A

Fig. 4 B

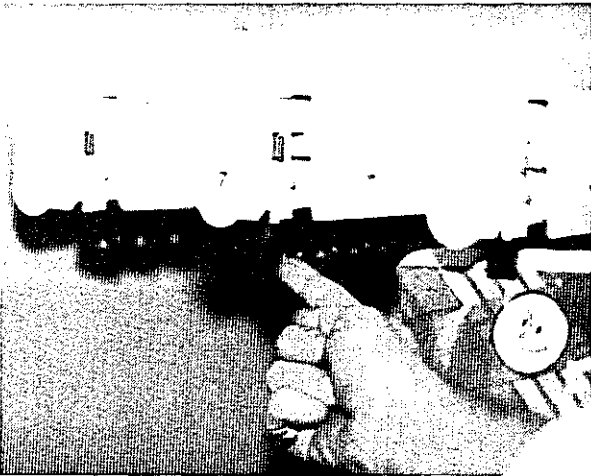
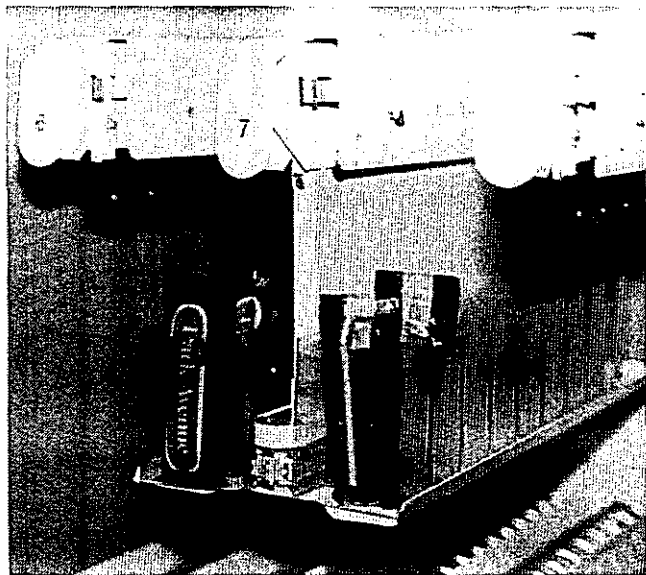

Fig. 4 C

CONFECTIONARY DISPENSER:

To load, release the latch and pull slide forward to stop. Place product into each dispensing cup starting with the left front cup and working backwards around to right back cup and then forward on the right side. Since the cups rotate left to right, the product on the left should face forward and those on the right should face backward to assure proper fronting (FIGURE 5). With all positions loaded, slide dispenser back into the machine until the latch snaps soundly into place.

Fig. 5



HELIX TRAY DISPENSERS:

NOTE: There are various types of trays as well as sizes of helix pitch. To assure proper operation and maximum capacity, the product size should closely match the opening between the winds of the helix. The product should fit between the winds of the helix so as NOT to be tight but should fill most of the opening.

Helix selections listed below may be utilized:

- 1" Helix (Thin Candy Bar)
- 1 3/8" Helix (Cigarette, Medium Candy Bar)
- 2" Helix (Large Bag or Candy Bar)
- 2" Helix Counter Rotating (Pastry Tray)
- 1" Split Helix (Gum and Mint)

To load, locate spring latch just under front edge of tray - push upward with finger while pulling forward on tray (FIGURE 6). Pull tray out until it hits stop.

At this point, check that each helix is in its detent position. FIGURE 7 shows the detent position of various types of helixes as they appear when properly timed. For proper timing see page 9.

Starting at front of tray, insert product between each wind of the helix so that the name of product is displayed frontward. Be sure to place product all the way to the bottom of the tray and lean free end at top backwards. (FIGURE 7) Fill from front to back and be sure not to miss any positions.

After filling, push tray back in all the way until the spring latch is engaged. Check that latch is fully engaged by pulling forward on tray.

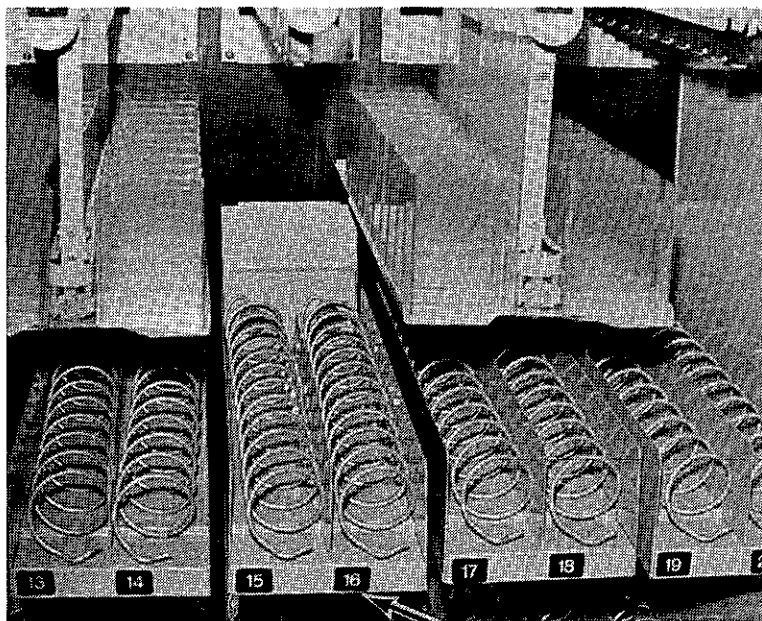

Fig. 6

Push up on spring latch and pull tray forward

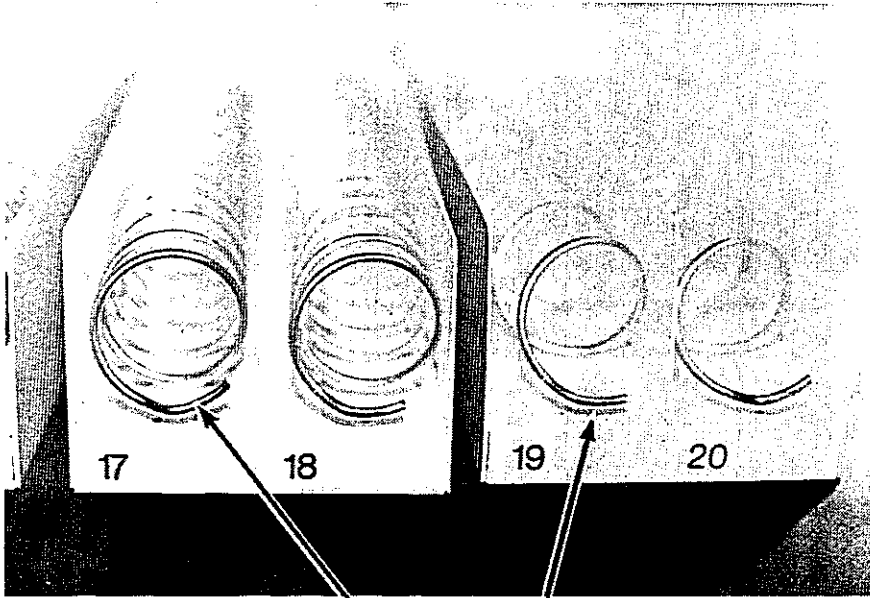

Fig. 7

Helix in detent position

Place Product on tray bottom - tilt product toward back of machine.

DISPENSER TIMING:

Another feature of the 30 selection merchandiser is a spring clutch inside the motor cam/gear housing. If a delivery mechanism should bind or be restricted by improper loading, the motor clutch will slip and allow the motor to complete its cycle. This will allow the remaining selections to be vended.

A wedge chain that has been restricted during cycle is detected by observing that a wedge link is not entirely up behind the plastic number tab. (FIGURE 9) To retime module, remove the restriction and all product from the chain. Remove the plastic number tab. Grip the chain and push backwards until the spring clutch engages. (FIGURE 10)

A confectionary module restricted during cycle is detected by observing that the two cups in front are not parallel. To retime the confectionary module, turn the module backward (rotate to the left) until the spring clutch engages.

A helix module restricted during cycle is detected by observing that the end of the last helix turn is not in the same position as the other helixes (FIGURE 11). To retime the helix, remove the restriction and turn the helix backward (counter clockwise) until the spring clutch engages.

After reloading any dispenser which has been retimed, cycle 3 or 4 times to ensure proper operation.

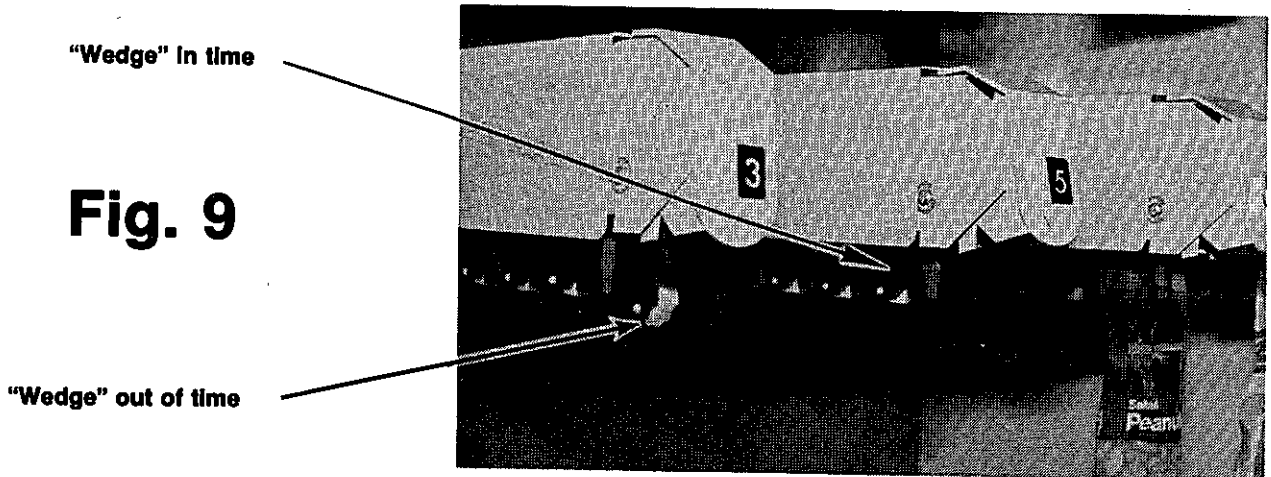

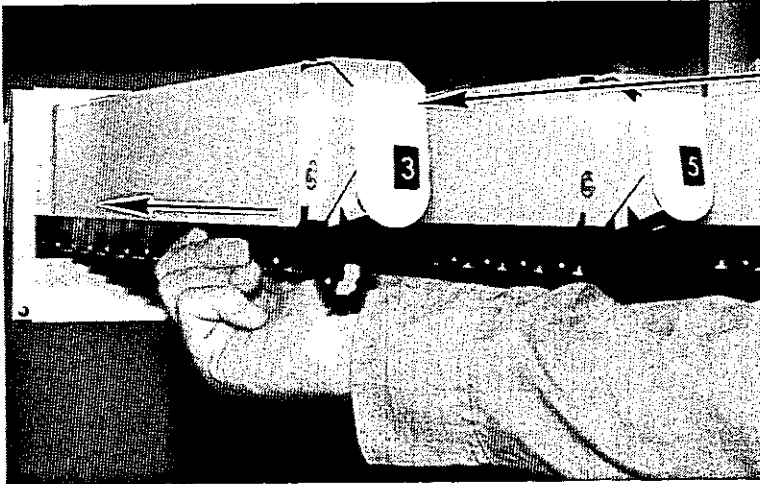

TO RESET TIME:
Remove number tab
and push chain back

Fig. 10

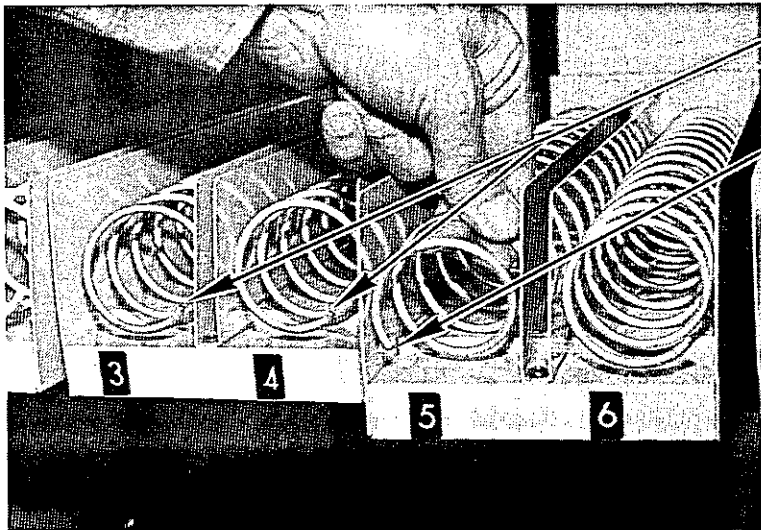

"Helix" in time

"Helix" out of time

Fig. 11

TO RESET TIME:
Rotate Helix Backward until
clutch "clicks" into place

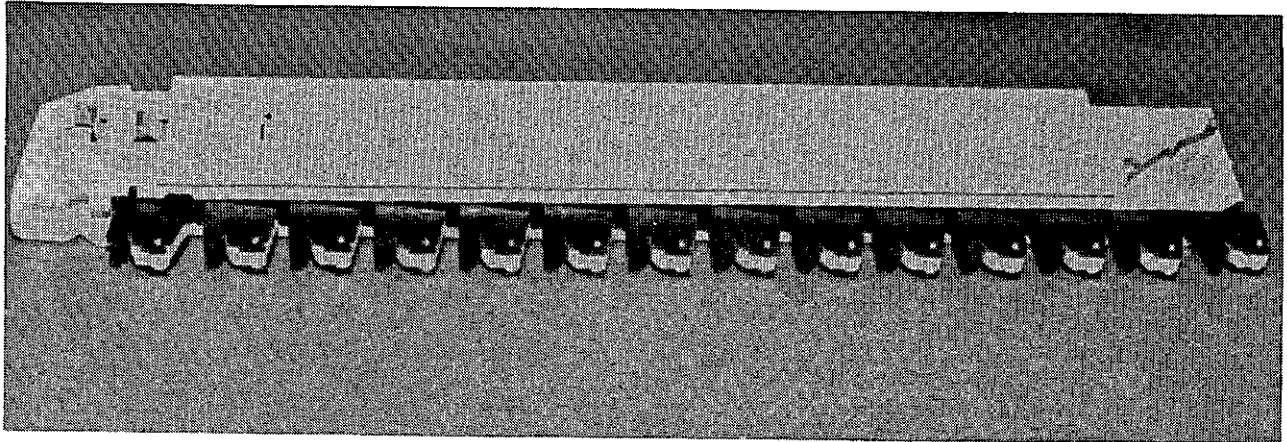

Fig. 12

WEDGE MODULE

FIGURE 12 illustrates the wedge chain dispenser use 30 Select Machine.

When a product selection is made, an electric signal from the selector switch starts the motor, and a carry over circuit through the switches of the motor completes the 180° rotation advancing the dispensing chain one step. As the leading chain segment moves around the front sprocket, the connector of the following segment acts as a lever to activate the white slide and lifter of the front segment, forcing the spring loaded cylinders upward. This upward movement releases the wedged grip maintained on the merchandise bag, and the bag drops to the delivery compartment, completing the vend.

In a previous section on loading, a warning was given about pulling products out of the dispenser. If a brute force pull in a downward direction is used, it will cause the metal cylinders to seat against the plastic dispenser chain segment. The product cannot be released and the module may hang in cycle which causes the selection to be inoperative. A good indication of someone pulling on the bags is chain parts found laying loose in the machine. Even if less force is used, tolerances will be changed, causing eventual failure of the dispensing chain.

The correct way to remove product is actually easier, and consists of pushing up on the white-colored release lever immediately behind the product. This causes the product to fall into your hand without harming the dispenser.

There is a particular type of bag made of glassine material that cannot be vended with the Polyvend wedge chain. This is a coated material that covers the metal cylinders with wax causing the bags to fall out freely.

Occasionally, dispensing chains must be replaced or repaired. The following illustrates the sequence of operations to accomplish this task.

- Release the latch on the dispenser and pull slide out to its stop. (FIGURE 13)

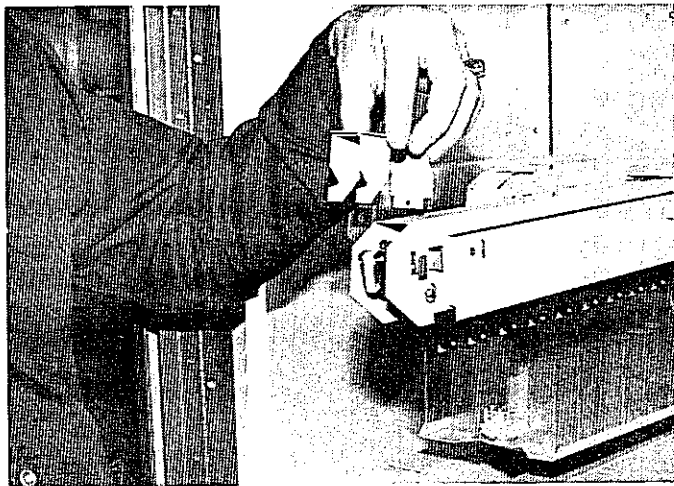
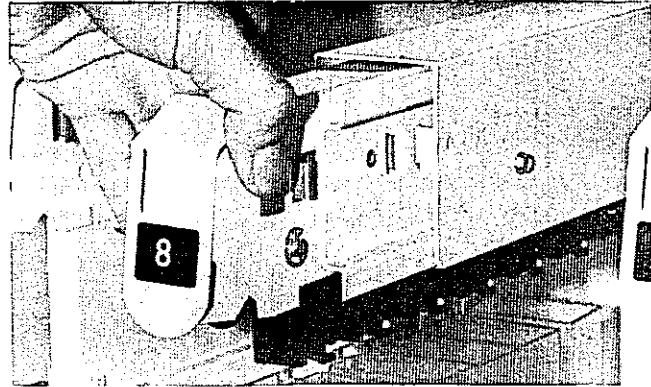

- Remove the dispenser number and price cover. (FIGURE 14)

- Remove the screw from the side of the dispenser (FIGURE 15) which serves as the stop and pull slide from the machine.

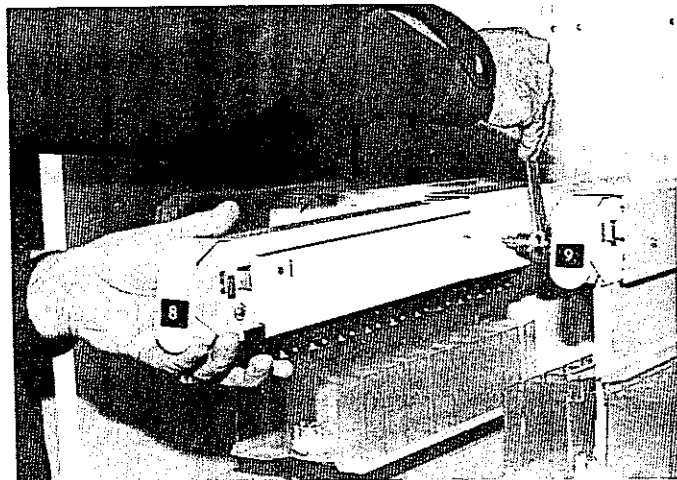

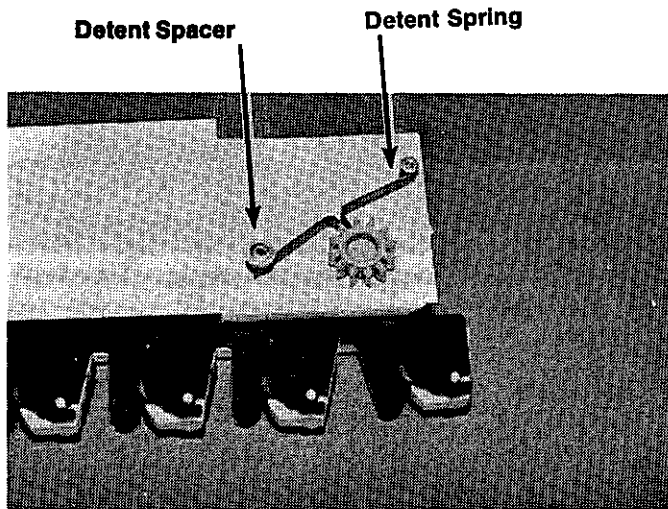

- Release the detent spring by pushing the flat end down and pulling it out from under the detent spacer. (FIGURE 16)



- Point front end of slide up and grasp the chin with thumb and fingers. Pull the chain support pin up and over the chain support slide while rotating the chain backward to normal rotation. Repeat until eight (8) pins are on top of the slide, which will allow enough slack to unhook the chain. (FIGURE 17)

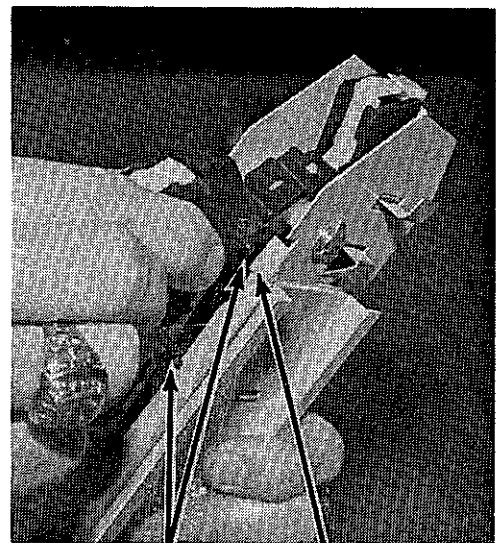

Support Pin

Chain Support

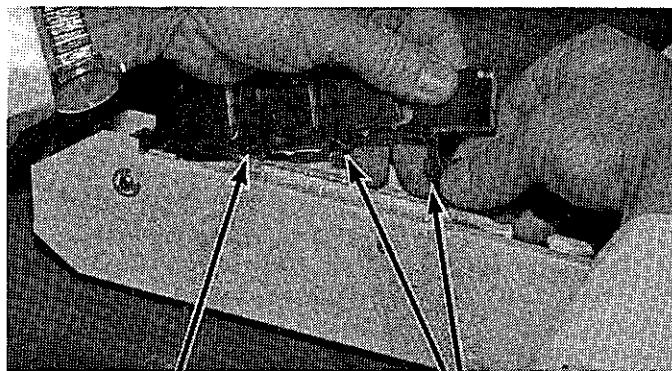

Support Pin

Snap Connector

- Unhook chain by grasping one link near the support pin and the next link near the snap connector - then gently twist the chain until it snaps loose. (FIGURE 18)



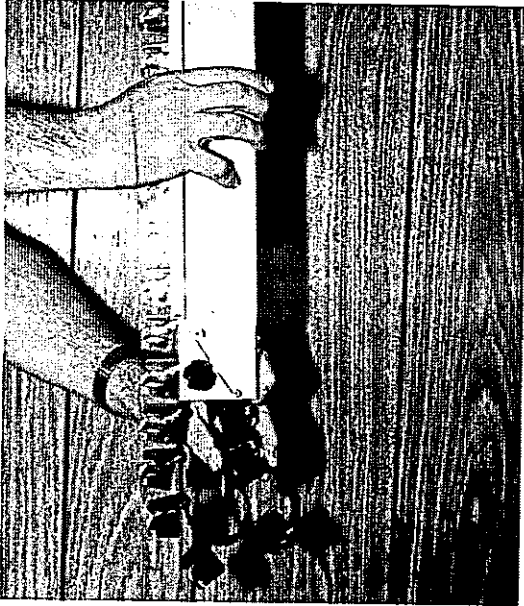

- Hold slide vertical with the front end up, and the chain will fall free of the inner portion of the slide. (FIGURE 19)



- Still holding slide vertical, lift bottom of chain outward and away from the slide. Push upward. The chain should easily slide free. (FIGURE 20)

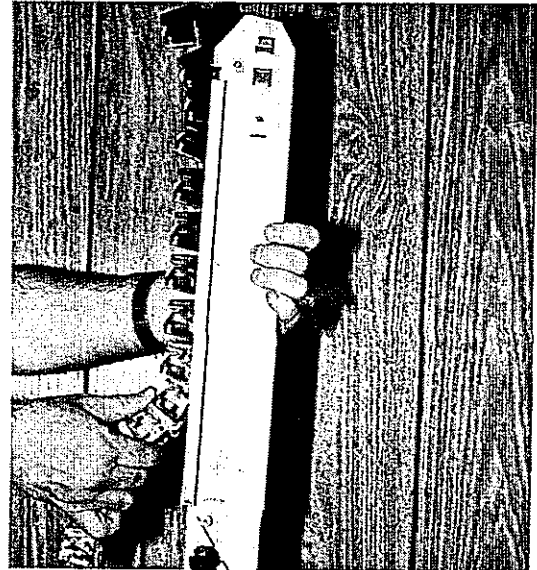

WEDGE ASSEMBLY REPAIR (FIGURE 21)

To repair the assembly and replace damaged components, remove the chain and snap out the damaged link.

This link is made up of the basic chain housing segment (Black), a cylinder lifter (White), a slide (White), two cylindrical wedge components and a compression spring. (FIGURE 21)

To disassemble, hold the link between both hands and push the cylinder lifter stub shafts outward with both thumb nails. It will pop out (retain with fingers) and may be removed. Next, the slide may be removed. Take care the compression spring isn't lost as the slide is removed. Now, the spring will fall free and the cylindrical wedge components will follow when the link is inverted. When reassembling the lifter, be sure the "flat" edge is against the cylindrical wedge and **not** against the slide.

All that remains is to reassemble using replacement parts as necessary. When the link has been repaired, snap it back on the chain.

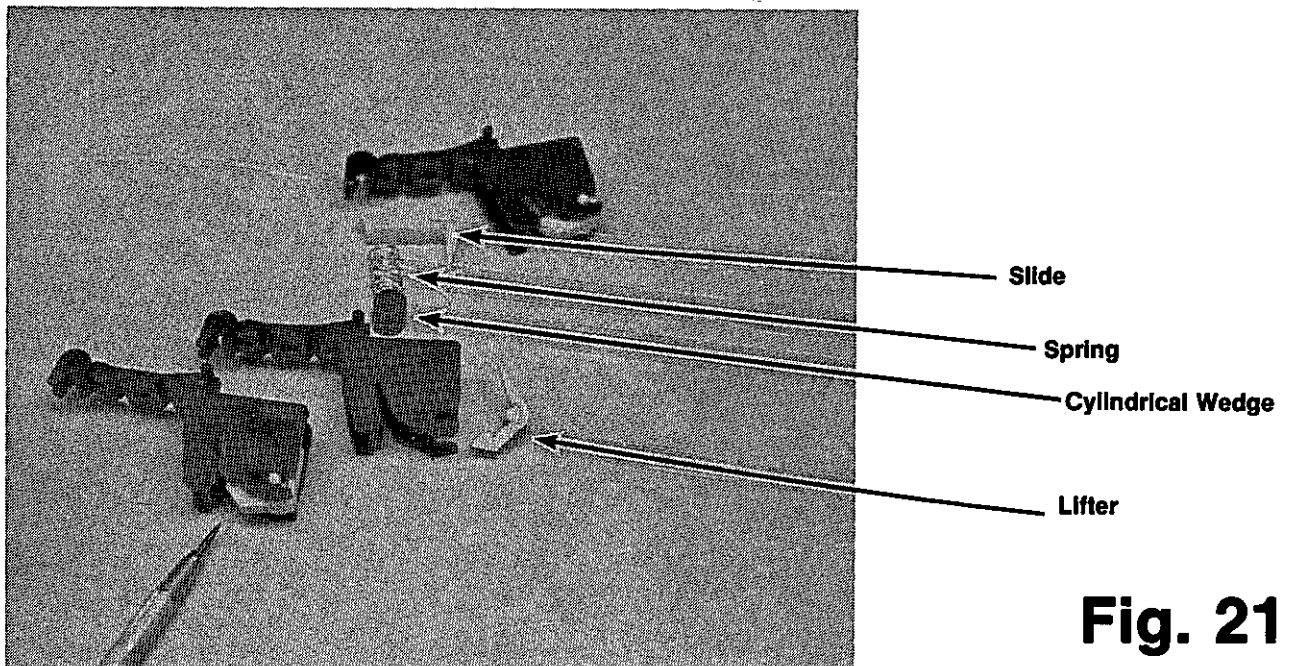

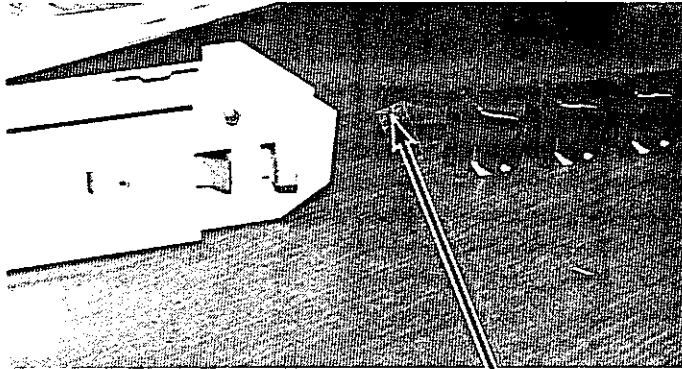

- To replace chain, lay dispenser on it's top and insert the chain end through the front of the module. (The snap connector end must be inserted from the front as shown or chain rotation will be wrong.) Continue pushing the chain through the dispenser until equal lengths of chain are sticking out each end. (FIGURE 22)



Snap Connector

- Grasp both ends of the chain and pull it over the bottom of the module. Push the white color slide out of the way and push the snap connector onto the support pin. (FIGURE 23)

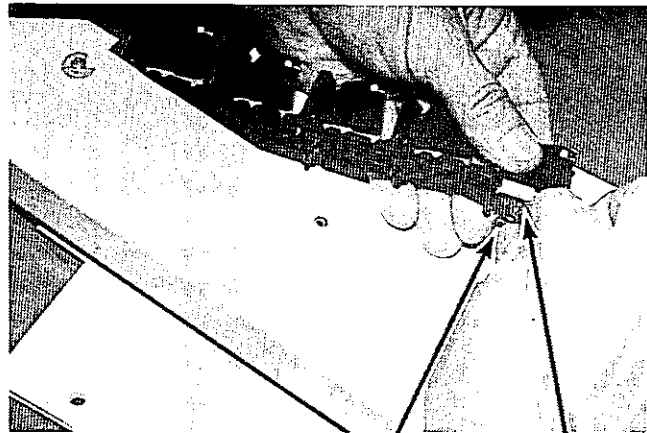

Snap Connector

Slide

Detent Sprocket

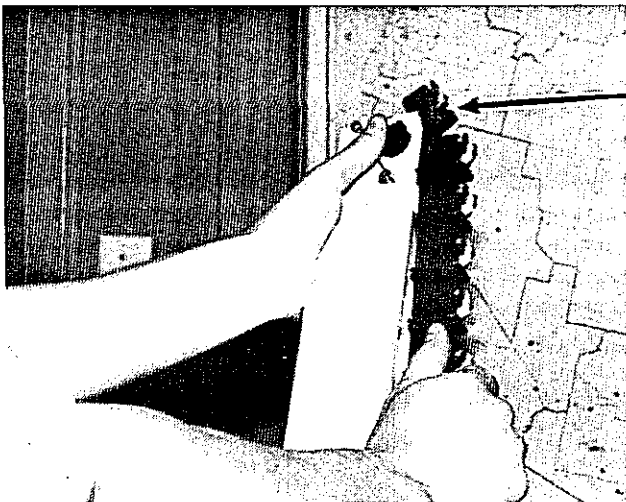

- To place the chain guide pins in the chain support slide, grasp the chain with one hand and rotate it in the direction of **normal** rotation, while holding the detent sprocket in with one thumb. (FIGURE 24)



- Continue pulling the chain until 3 complete revolutions have been made. Position the first link of the chain as shown and engage the detent spring with the drive gear.
(FIGURE 25)



Position 1st Link As Shown

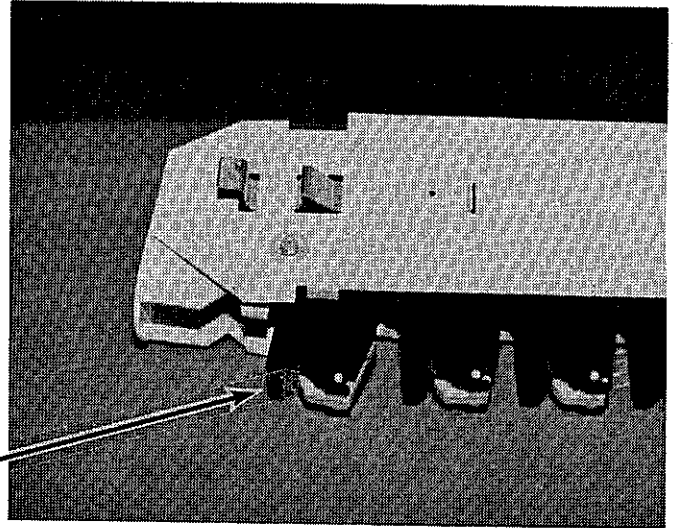

CANDY MODULE (CONFECTIONARY)

The candy dispenser slide assembly is removed from the machine in the same way that the chain slide assembly is removed. Just withdraw the stop screw and slide the assembly out of the machine.

CUP AND PLASTIC CHAIN REMOVAL

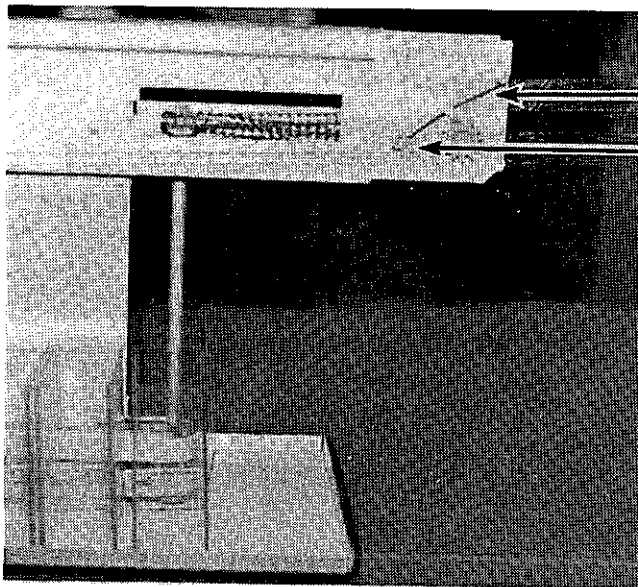

Detent Spring

Detent Spacer

- Release the detent spring by pushing the flat end away from the detent spacer and pulling the spring out from under the spacer.
(FIGURE 26)



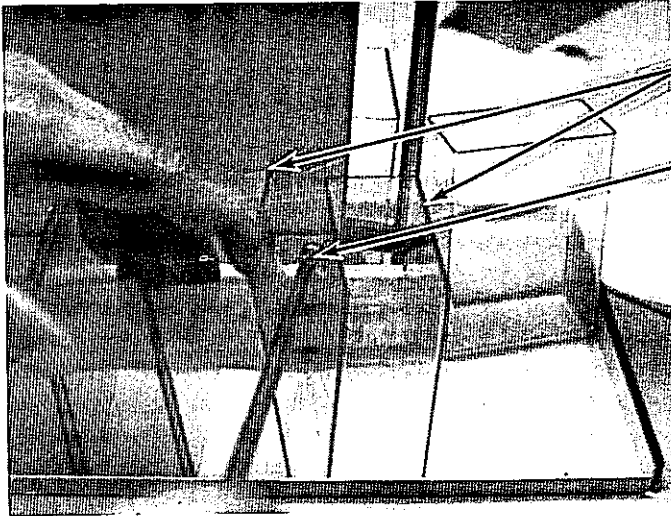

- The candy cup chain guide must be removed in order to remove the cups or the plastic chain. To remove the guide, remove the six (6) screws that mount the chain guide to the divider. For easy access to each screw, rotate the cups until the screw can be reached by pushing the cups apart. After all screws have been removed, lift the chain guide up to expose the chain links. (FIGURE 27)



- To remove the guide, gently pull the back half away from the divider enough to "unwrap" it from the divider. DO NOT bend the guide anymore than is necessary to remove it. Excessive bending can cause the guide to lose its round shape on each end and this will cause chain binding when it is re-installed. (FIGURE 28)

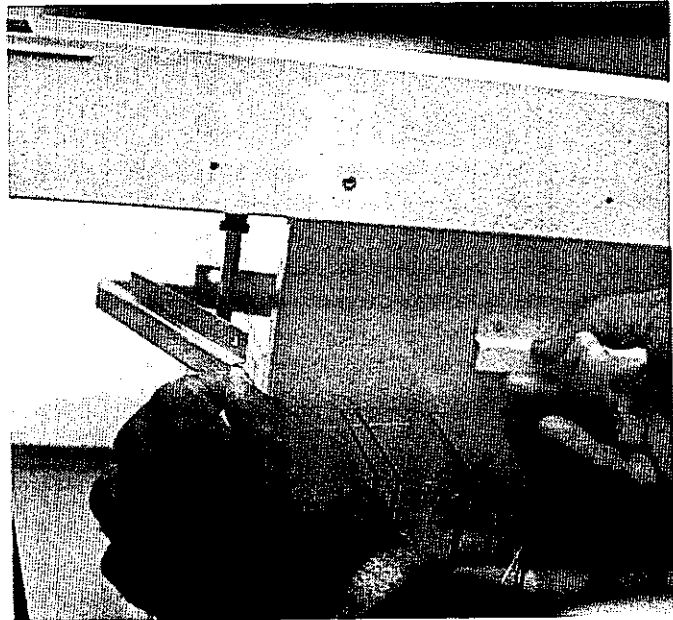

- Pull upward on the cups and they will snap loose. After all cups are removed, the chain can be removed by twisting the chain until it unsnaps. (FIGURE 29)

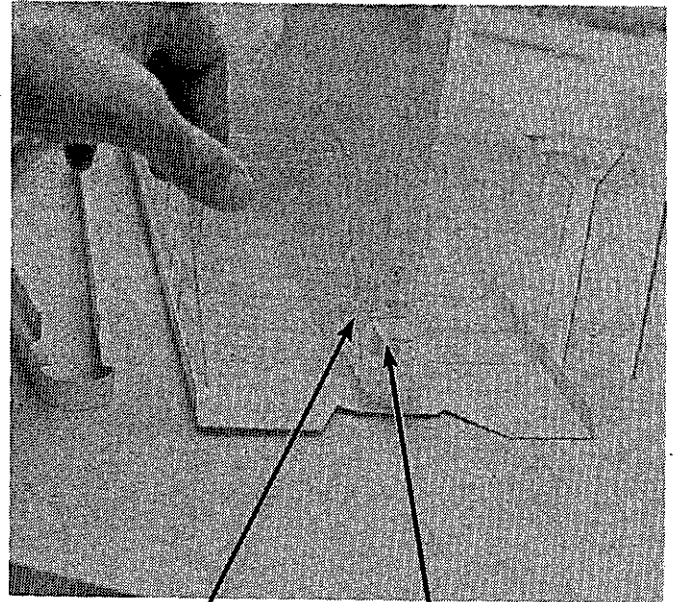

Cup Connector

Chain Pin

Chain Pin

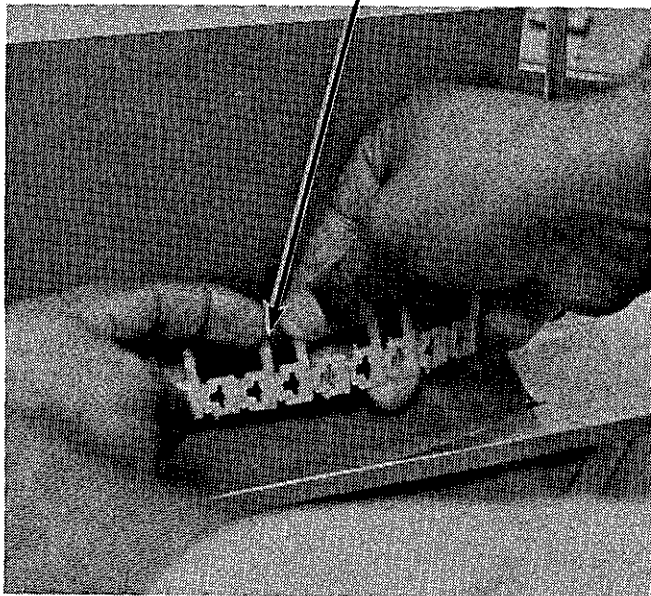

- After all cups are removed, the chain can be removed by placing a finger behind the top pin on one link while pushing the pin on another link with a thumb. The chain will snap apart. All damaged links can be replaced with new ones. (FIGURE 30)



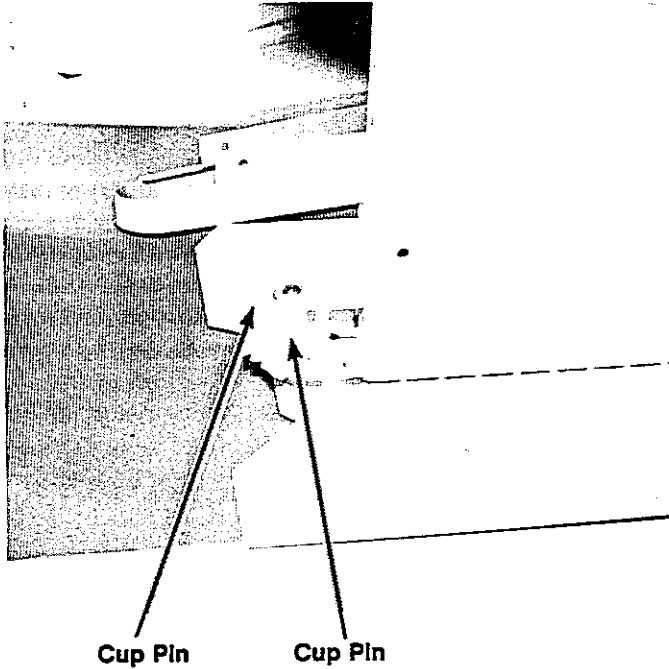

- After repairing the chain, reassemble all components, making sure there are 44 cup retainer links and 22 plain links. Place the chain around the front sprocket and align a pair of cup pins opposite each other, as shown. (This will assure proper timing of the cups when the chain is snapped together.) Without moving the front sprocket, pull the chain tight and wrap it around the back sprocket. (FIGURE 31)

- With the detent spring engaged, and the cup pins aligned opposite each other, snap the chain together. (FIGURE 32)

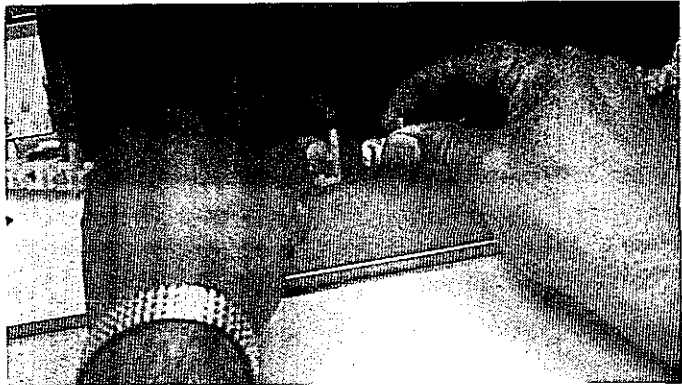

- To replace dispensing cups, snap the cups back on the chain pins. For easier installation, place two fingers under the chain while pushing the cups on with the other hand. Be sure the cups are pushed all the way down on the chain. (FIGURE 33)

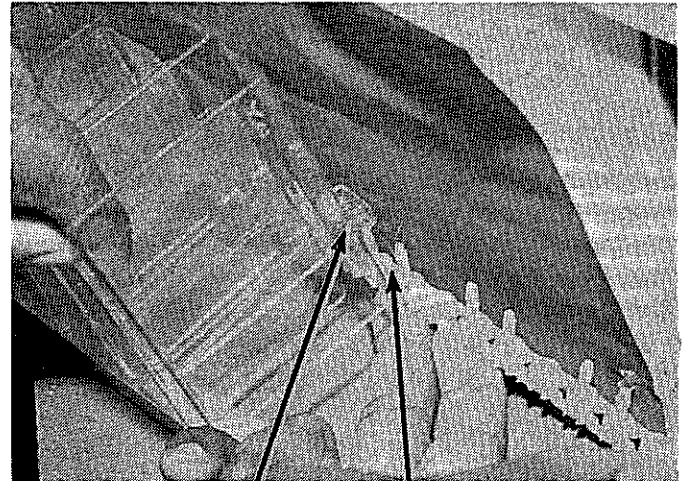

Cup Mounting Tab

Chain Pin

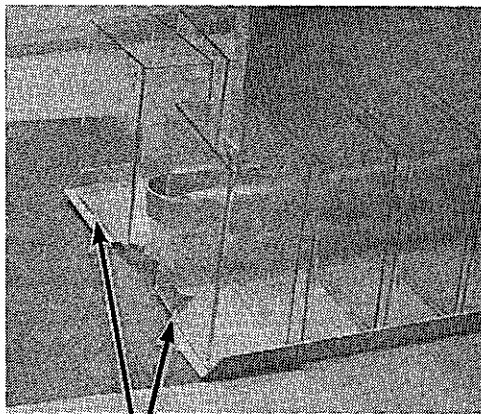

Correct Timing

- After all cups are replaced, check for proper timing. (The module is timed correctly when the detent spring is engaged and the front cups are parallel to each other. (FIGURE 24))



Re-install the chain guide, being careful not to bend it anymore than is necessary. Rotate the detent sprocket and check for chain binding inside the chain guide.

Re-install the candy module in the machine and tighten the stop screw on the module arm.

LADDER CHAIN REMOVAL AND REPLACEMENT

- To replace the metal ladder chain, pry the drive sprocket off the vertical shaft. The chain will hang free from the back drive sprocket. (FIGURE 35)



Drive
Sprocket
Vertical
Shaft

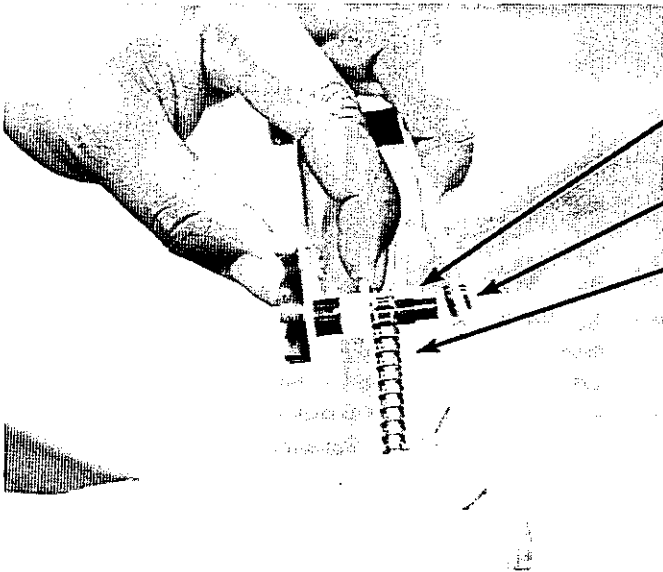
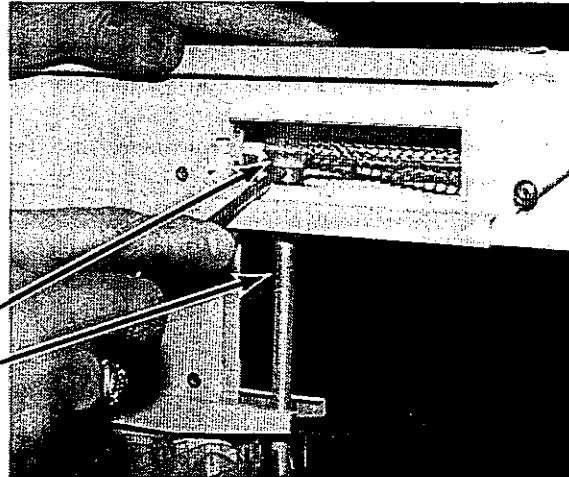

Shaft
Bushings
Chain

- To remove the chain from the sprocket shaft, pull the back sides of the slide module apart, allowing the sprocket shaft to slide out of the bushing. The chain will drop off the shaft. Place the new chain on the back drive sprocket and push the sprocket shaft through its bushing. (FIGURE 36)



- To re-install the drive sprocket on the vertical shaft, hold the sprocket so the **flat** side of the sprocket shaft hole is facing the **flat** side of the shaft. Pull the chain through the slide access hole and "twist" the chain ¼ turn and place it on the sprocket. (The chain must be "twisted" as shown or the cups will rotate backward. (FIGURE 37)



Flat side

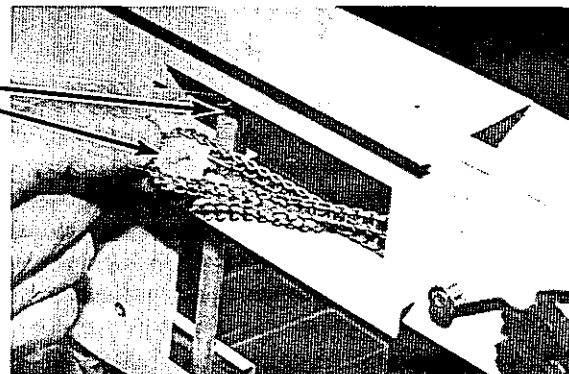

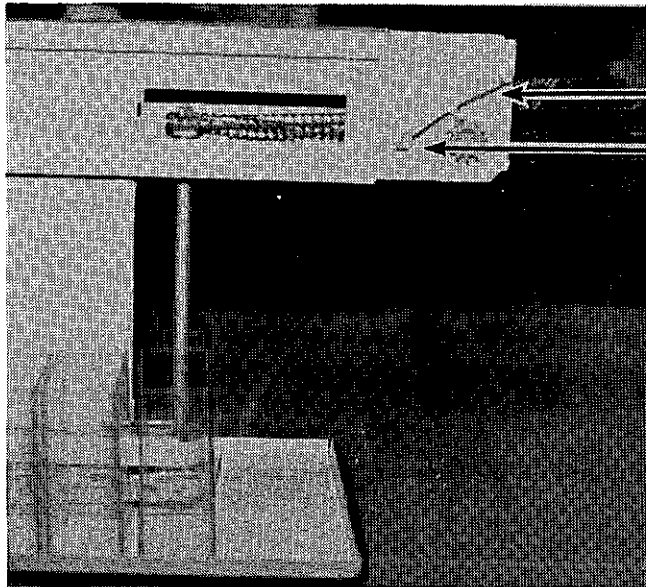

Detent Spring

Detent Spacer

- With the chain around the sprocket, place the sprocket on the vertical shaft. Be sure the sprocket is pushed down all the way on the shaft. (FIGURE 38)



- To time the module, position the cups so the two front cups are parallel, and be sure the detent spring is engaged. (FIGURE 39)



Cups

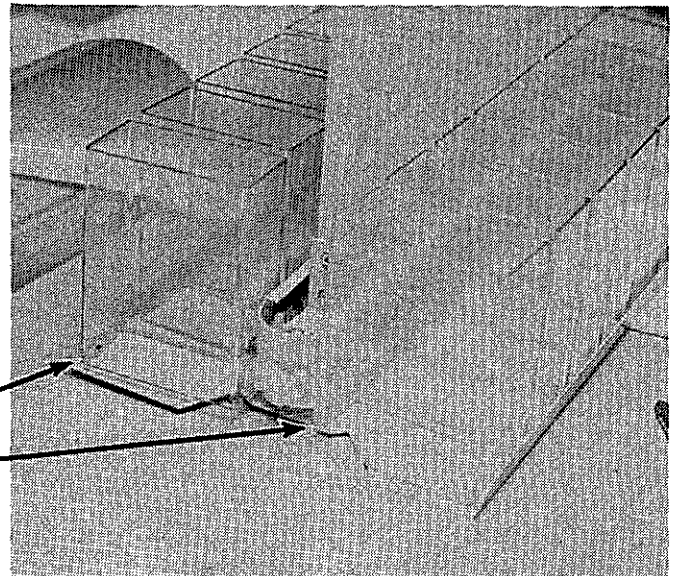

Reinstall the module in the machine, tighten the stop screw, and cycle the machine 3 times to insure proper timing.

HELIX MODULE

The helix sliding tray has a detent latch on the back of each tray. (FIGURE 40) The function of this latch is to hold the helix in position when the tray is released and pulled forward for product loading.

After the tray is pulled forward, each helix should be checked to see if the detent latch is engaged. This is done by trying to rotate each helix, if it does not turn, the latch is engaged.

To change helix sizes within a sliding tray, loosen the small set screw in the drive hub, remove and replace helix, center helix on hub and retighten the set screw.

Fig. 40

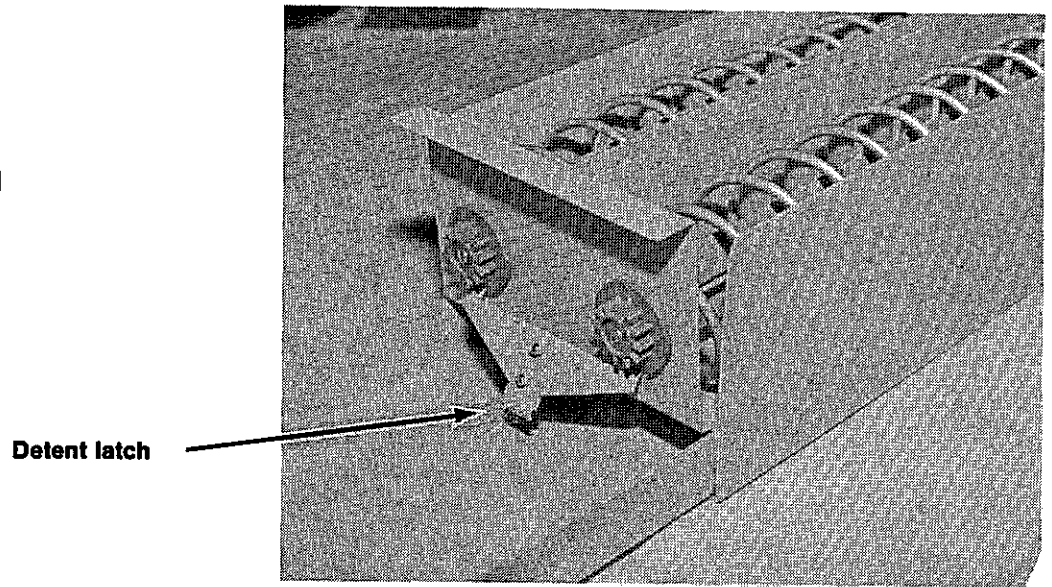

ELECTRICAL

The 30-select merchadiser operates from a primary power source of 115 volts, 60 cycle A.C. reduced through a transformer to a secondary source of 24 volts A.C. which supplies power to the machine circuits with the exception of the fluorescent lighting. The electrical schematic shows the entire system.

When the service cord is connected to 115 VAC, the current is first routed through a 2 AMP fuse located on the tilt-out power panel (FIGURE 41). This 115 VAC then powers the ballasts and starters to operate the 15 watt top and side fluorescent lamps. These lamps stay on continuously unless the machine service cord is disconnected or the 2 AMP fuse is blown. To replace fuse, rotate cap counter-clockwise and pull out.

The other electrical components operate on the 24 VAC secondary supply through a 3.2 AMP fuse and from the transformer mounted inside the control panel.

Two types of D.C. motors are used on the thirty select merchadiser (FIGURE 42). A 180° clockwise rotating motor and a 360° counter-clockwise rotating motor. Refer to helix and wedge module diagrams for reference to different types of motors and their uses.

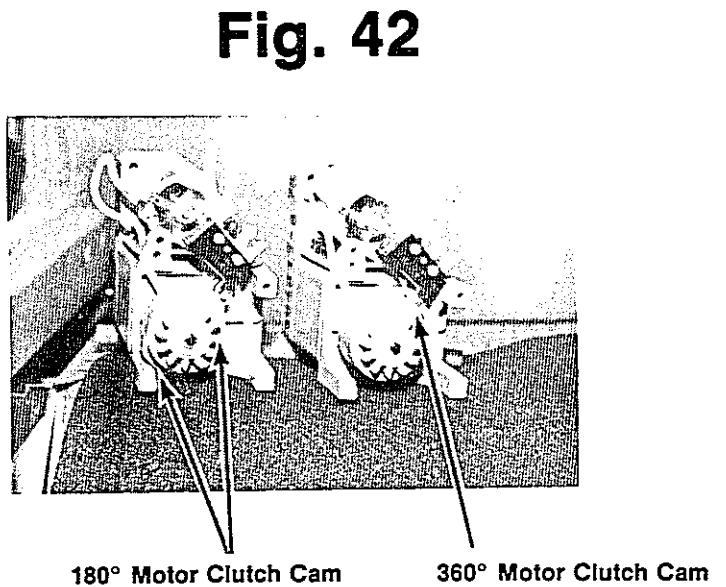
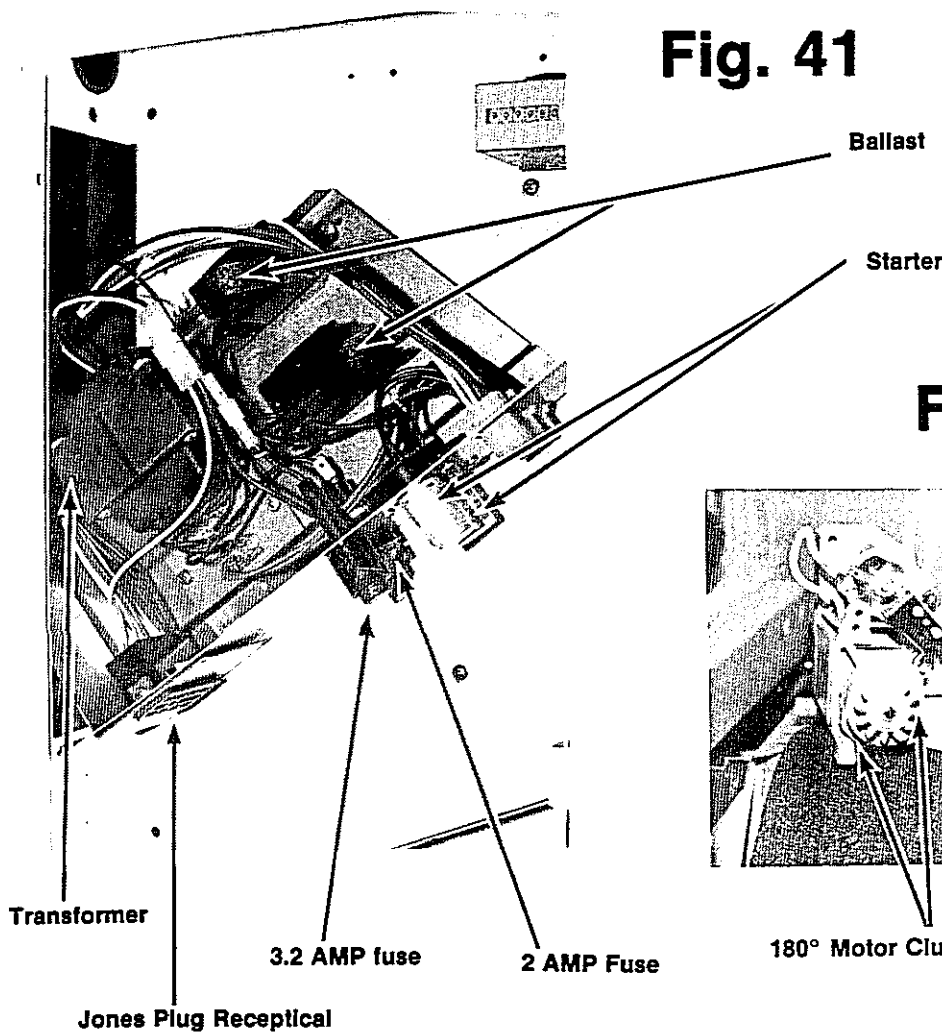

TROUBLE SHOOTING

- **MACHINE WILL NOT ACCEPT COINS:** Remove/rejector to visually inspect 5¢/10¢ blocking fingers in coin changer.
 - 5¢/10¢ blocking fingers **are** magnetically retracted:
 - Be sure the machine is level.
 - Be sure the changer is properly installed.
 - Be sure blocking fingers are adjusted properly - not protruding into the acceptor/rejector.
 - Acceptor/rejector needs cleaning or adjustment, clean, repair, or replace.
 - 5¢/10¢ or 25¢ blocking fingers **are not** magnetically retracted:
 - Make sure machine is plugged into 115 volt outlet. (Are fluorescent lamps on - check 2 amp fuse)
 - Make sure changer Jones Plug is securely connected.
 - Be sure each motor plug is securely connected.
 - Check wires connected to the motor switches.
 - Main motor harness must be securely connected.
 - Check manual payout on changer. If it does not operate, check red cap fuse. If blown, check for short or ground on 24 volt circuit. Transformer may be defective.
- **MACHINE WILL ACCEPT COINS BUT.**
 - No selection can be made.
 - Check connector engagement from selector switch assembly to harness.
 - Check brown or red wire between harness and selector switch.
 - Check plug to price setting board.
 - Only some selections can be made.

NOTE: Identify all non-operable selections by number and their relation by price setting, position in machine or position on selector switch.

 - Check for proper price settings.
 - Check for defective selector switch assembly. The selector switch is wired in series starting at position #1 and running down the left side through the odd numbers. A jumper then connects to position #2 and the series circuit runs down the right side through the even numbers. A defective selector switch is indicated when a sequence of selections in the series does not operate. EXAMPLE: Selections #1, #3, #5, and #7 can be made but the remaining selections cannot. The selector switch is defective between positions #7 and #9.
 - Substitute a coin mechanism and see if the problem is corrected, if so, one of the price levels in the changer is defective.
 - Check for defective dispensing motor(s).
 - Check to see if selection that will not operate is timed properly. If a motor clutch has slipped, (module out of time) the motor will not run until the module is retimed.

- **COMMON FAULTS**

- An empty wedge, cup or helix position. Reported as “machine did not work”.
- Not clicking the module back firmly. In this case the motor will turn without moving the dispenser.
- Displacement of back wedge on chain. The last position on the chain (the 13th) is not intended as a loading point and will force its load into the back of the cabinet when the module is pushed back.
- Pulling down too hard when loading the wedge. The wedge may jam or perhaps have its components displaced when vend occurs.
- Fluctuating voltage can cause the 3.2A 24V fuse to blow.

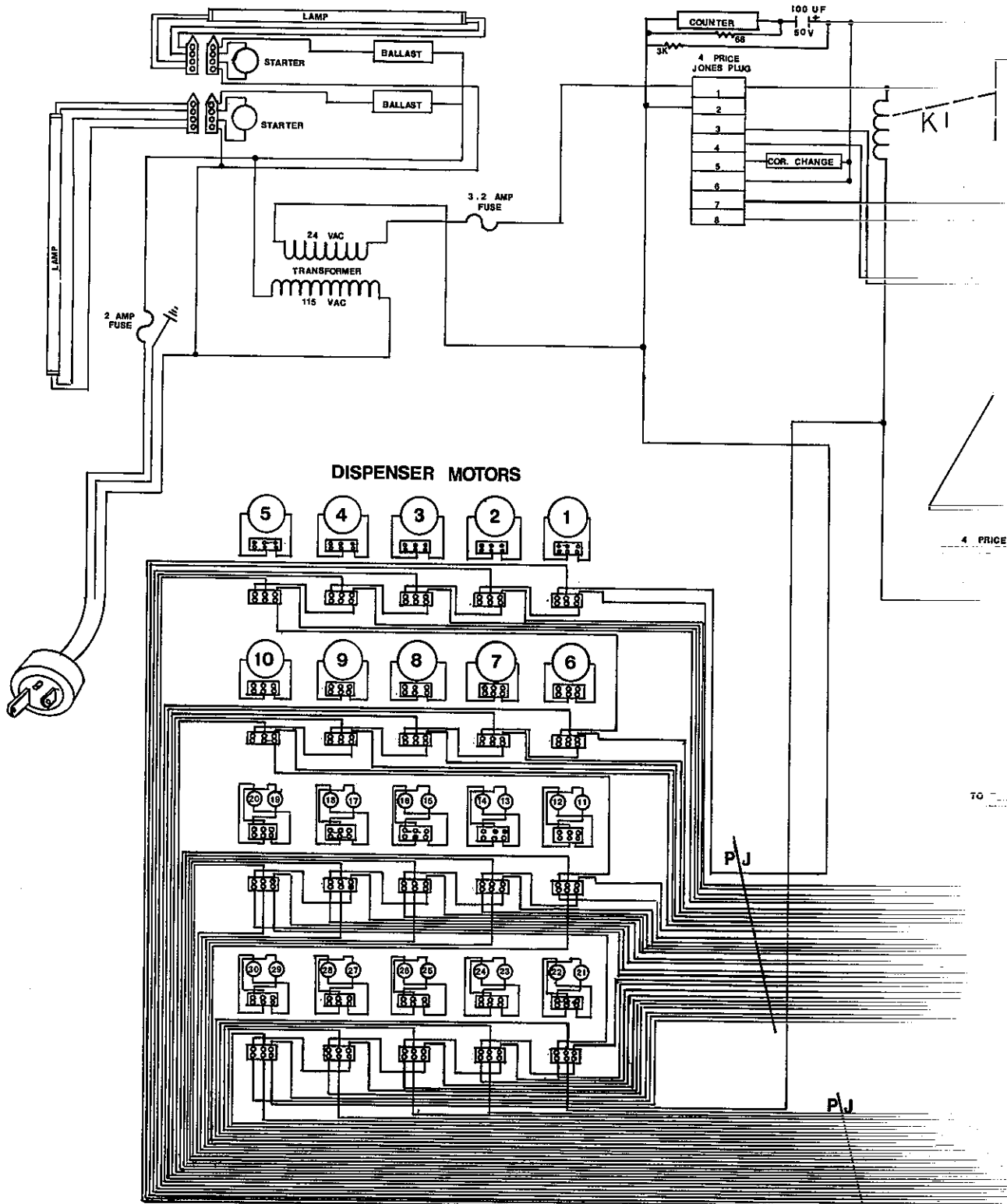

BACK VIEW

**30 SELECT
FOUR PRICE**

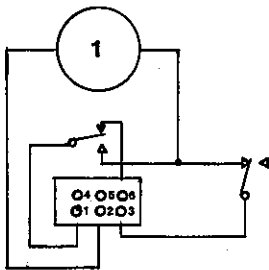
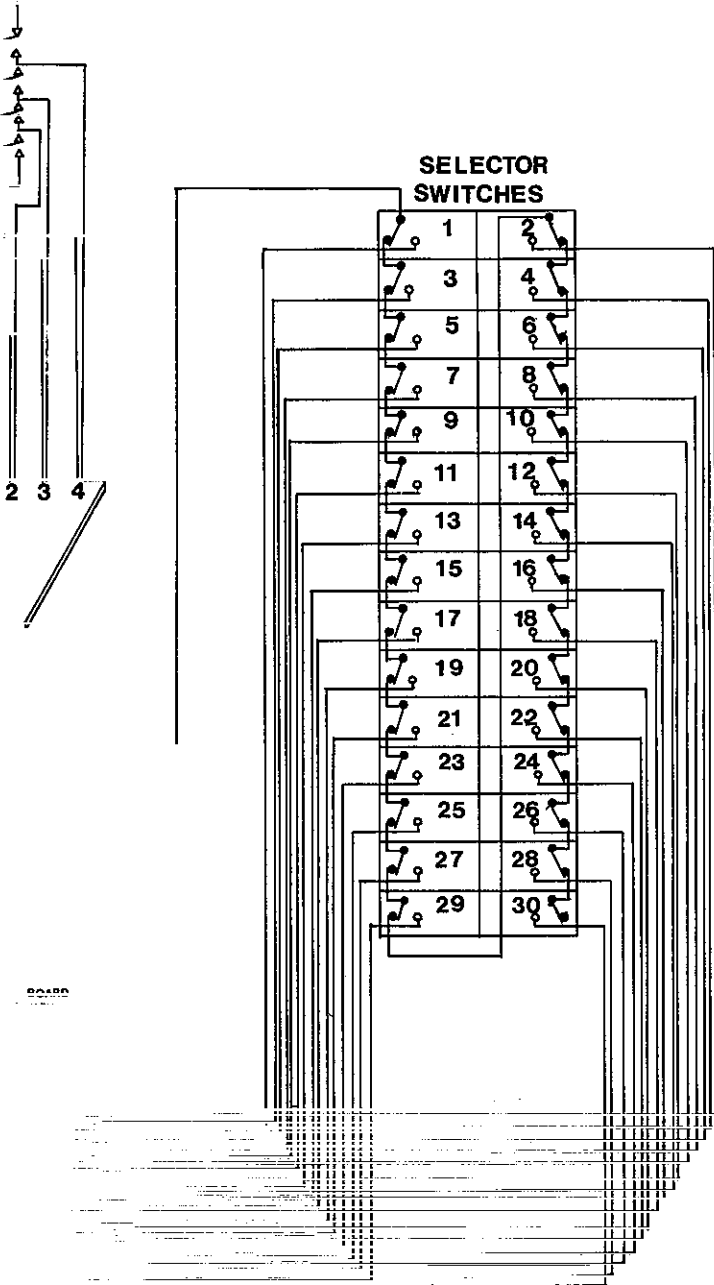

TYPICAL MOTOR WIRING
CIRCUIT SINGLE MOTOR

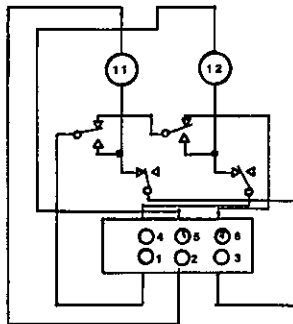

TYPICAL MOTOR WIRING
CIRCUIT DOUBLE MOTOR

**30 SELECT
MULTI PRICE**

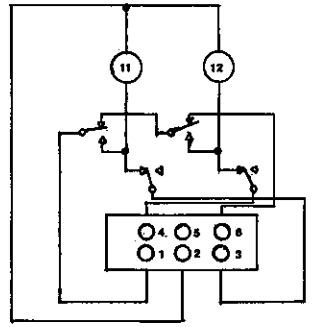
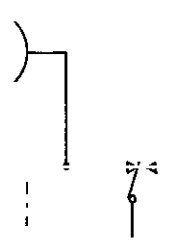
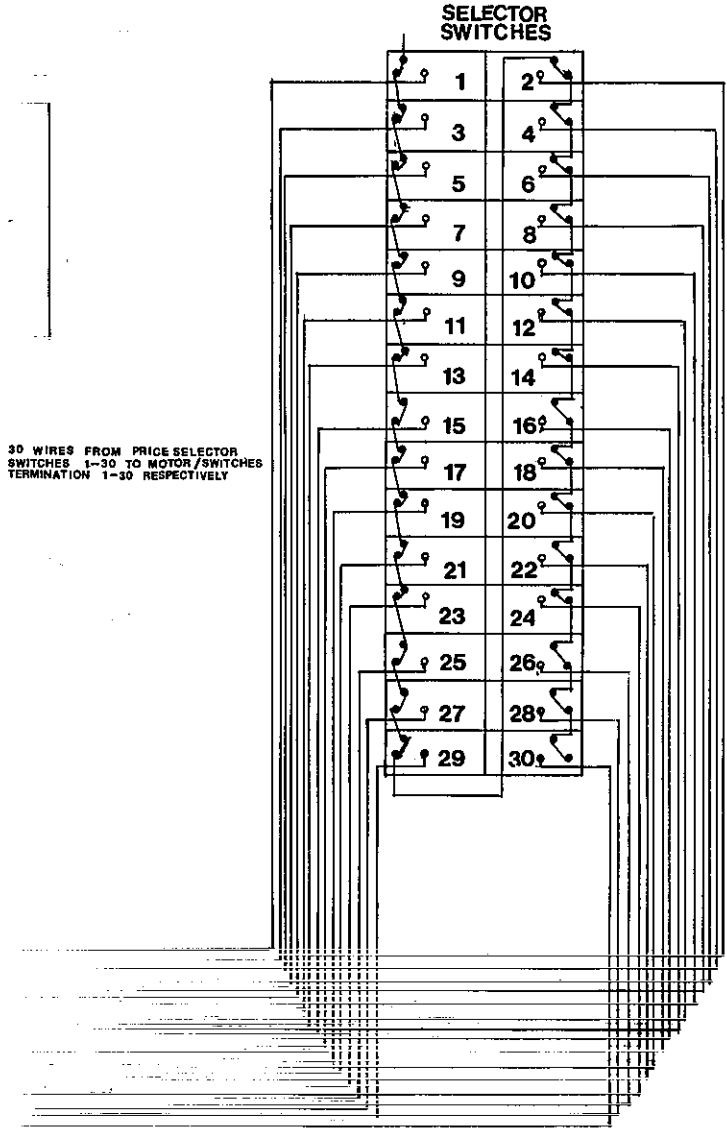

TYPICAL MOTOR WIRING
CIRCUIT DOUBLE MOTOR

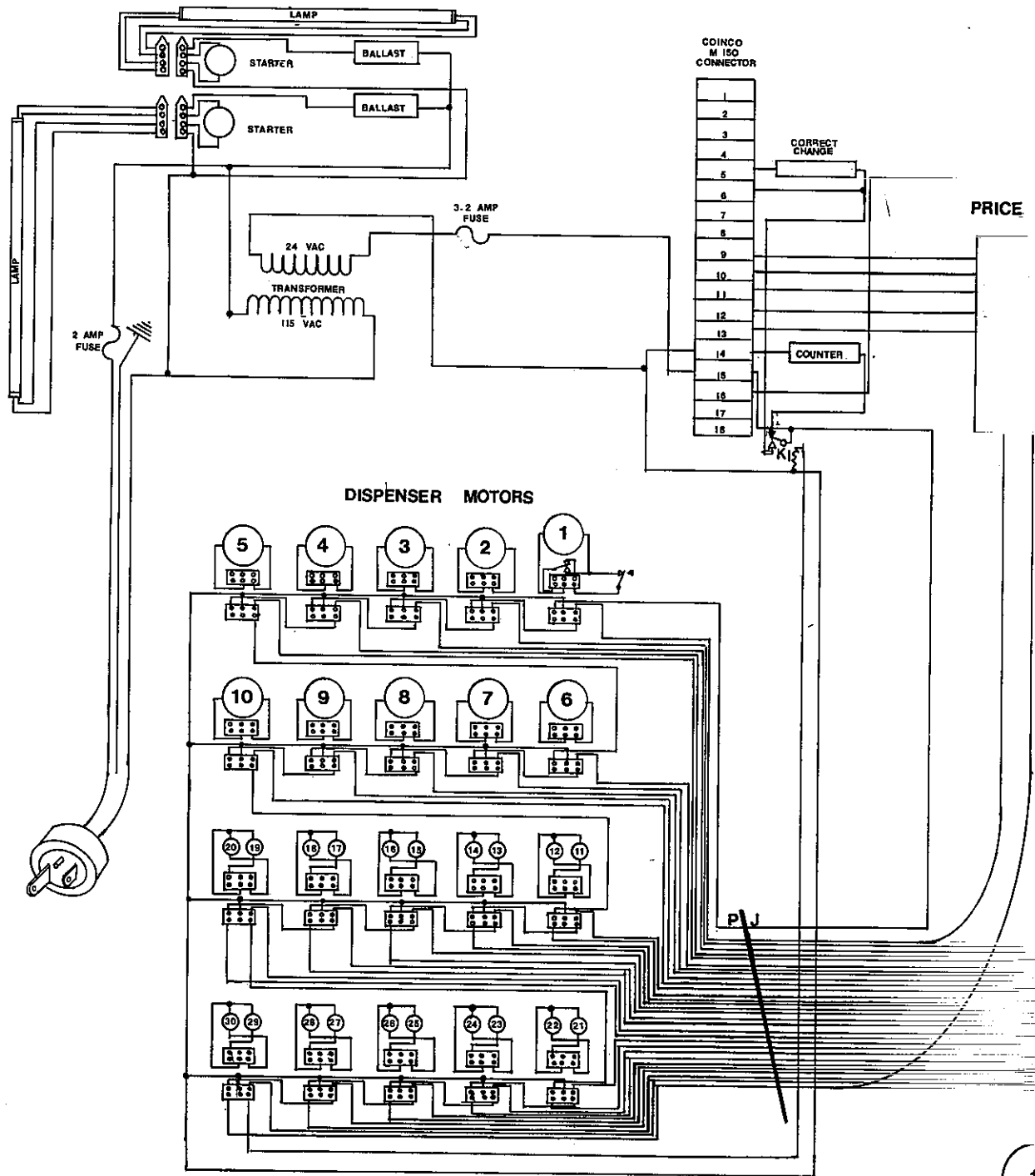

TYPICAL MOTOR WIRING
CIRCUIT SINGLE MOTOR

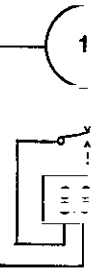

SELECTOR SWITCH

The 30 button selector switch is mounted inside the right front of the product compartment behind the sliding electrical compartment door. It may be removed by backing out four screws and disconnecting the wiring harness.

PRODUCT DELIVERY COMPARTMENT

This sub-assembly, including the "push" plastic door, may be removed from the front of the machine thru the product compartment. This may be accomplished as follows:

- Remove product compartment bottom. (5 screws)
- Remove left panel over delivery compartment. (4 screws)
- Remove the right side deflector. (2 screws)
- Remove 4 screws on the front inside edge of the delivery compartment. NOTE: Support the compartment while removing the last screw to prevent dropping.
- Lift compartment up and turn slightly to remove through the product compartment door.
- Reverse procedure to replace.

REAR ACCESS COVER (DOOR)

A large access cover is provided on the rear of the machine. Its major purpose is to permit access to the wiring harness in the rear of the machine. To remove, use one of the keys provided. Unlock it and lift off. (While pulling outward with key.) CAUTION: Do not allow door to fall freely as this could result in damage to the rear door.

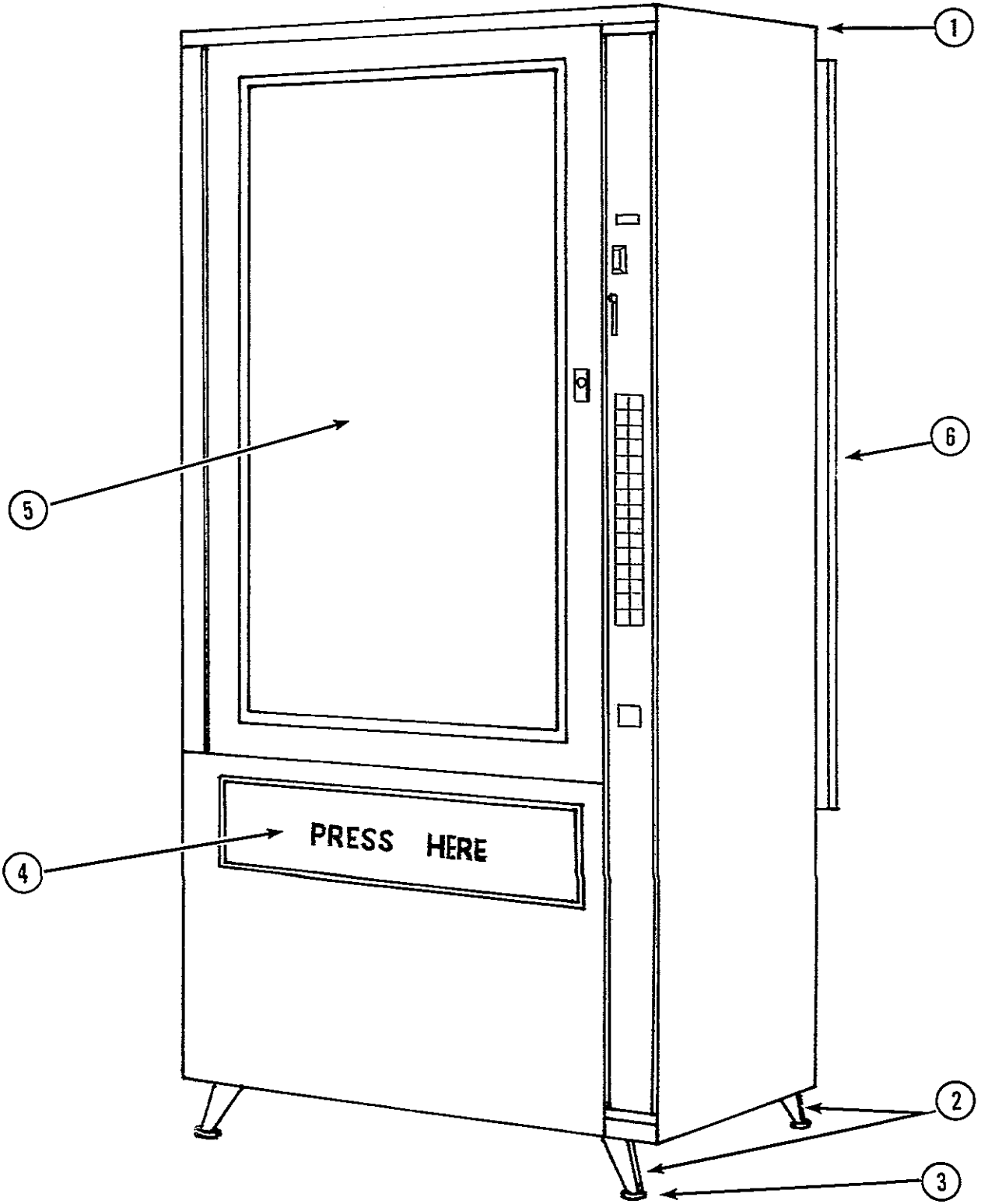

CABINET

ITEM	PART NUMBER	DESCRIPTION
1	Specify Color	Shell-Outer includes B-10338
2	10338-*	Leg & Plate Assembly (Specify Color)
	-01	Black Legs
	-02	Brown Legs
3	12766	Equalizer - Leg
4	See Assy. Drawing	Compartment Assembly - Delivery
5	3887	Service Door
6	10356	Door - Rear Assembly (Specify Color)

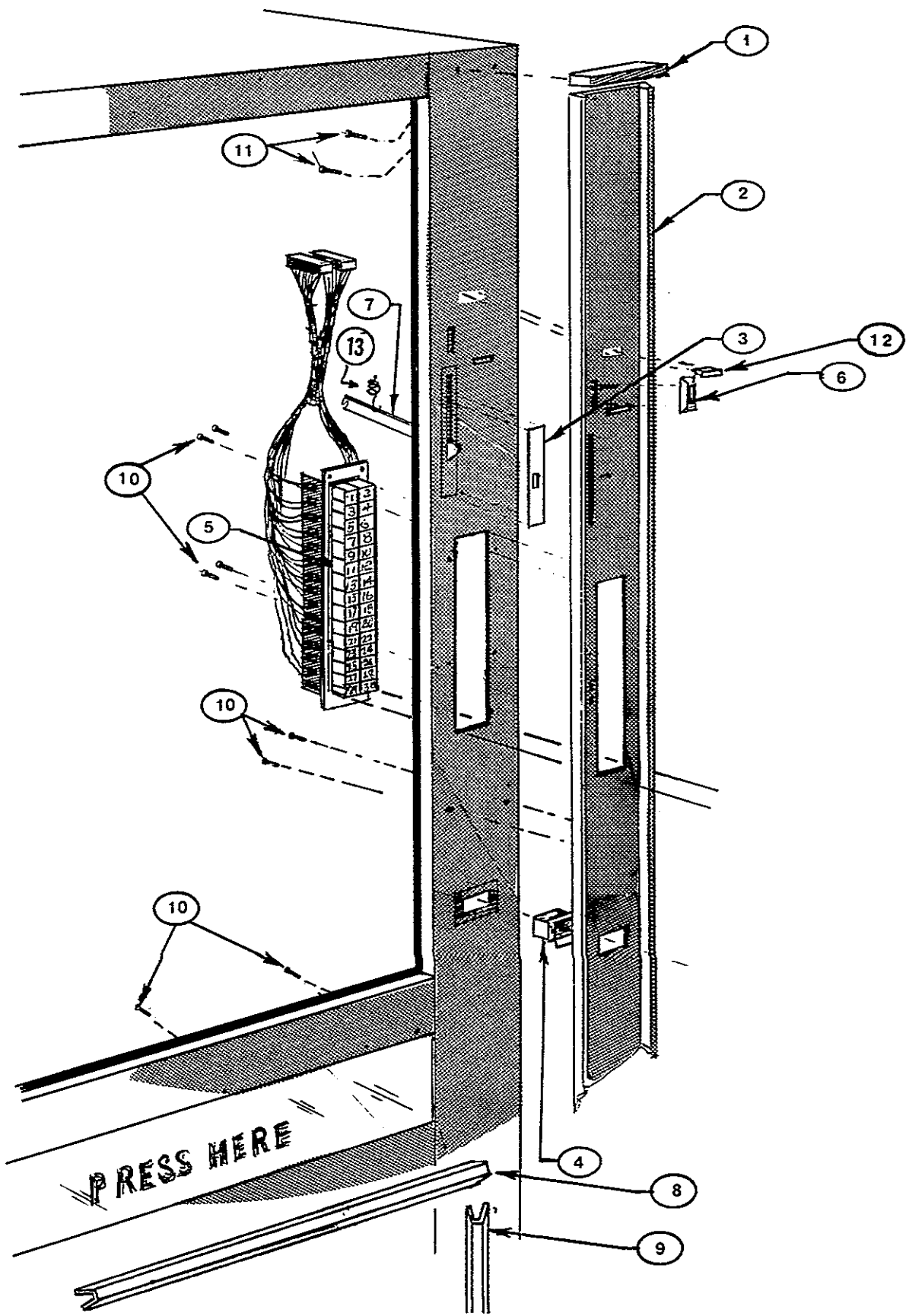

TRIM DETAILS

ITEM	PART NUMBER	DESCRIPTION
1	1380	Escutcheon End Cap
2	13063	Escutcheon Plate
3	1414	Plate - Reject Lever Cover
4	10432	Cup - Coin Return Assembly
5	12839	Switch Assembly - Selector
6	4949	Casting Coin Insert
7	13134-01	Lever Assembly - Reject
8	1470-01	Trim - Delivery Compartment, Top or Bottom
9	1470-00	Trim - Delivery Compartment, Side
10	1298	Screw - TP "AB" Pan #8 x $\frac{3}{8}$
11	11894	Screw - TP "23" Pan #8 - 32 x $\frac{3}{8}$
12	1616	Lamp - Indicator, "USE CORRECT CHANGE"
13	89	Spring - Reject Lever

NOTES

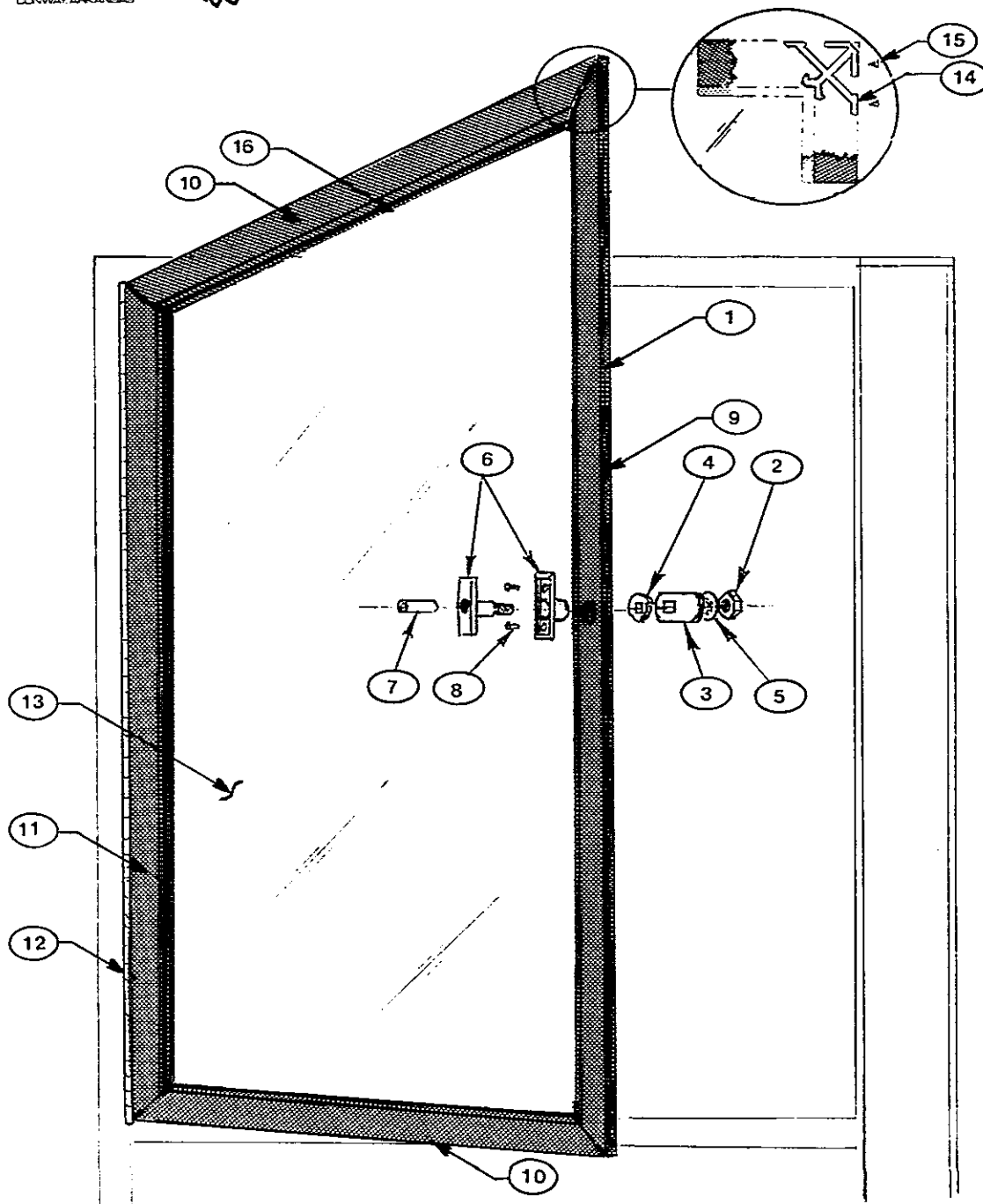

PRODUCT LOADING DOOR

ITEM	PART NO.	DESCRIPTION	ITEM	PART NO.	DESCRIPTION
1	3887	Door - Product Loading	9	11594	Door Frame, Lockside
2	11538	Nut - Hex Jam	10	11595	Door Frame, Top & Bottom
3	1483	Cam	11	11596	Door Frame, Hinge Side
4	11539	Stop Cam	12	11597	Hinge, Product Door
5	1680	Lockwasher	13	1924	Glass, Tempered 3/16" Door
6	11537	Handle Assembly	14	11598	Angle, Corner Frame
7	1809*	Cylinder - Inner	15	11599	Screws, #10 x .500 Flat
8	746	Screw	16	11600	Gasket, Vinyl - Glass
			2 thru 8	1490*	Lock Assy Complete

*NOTE: Please specify key number.

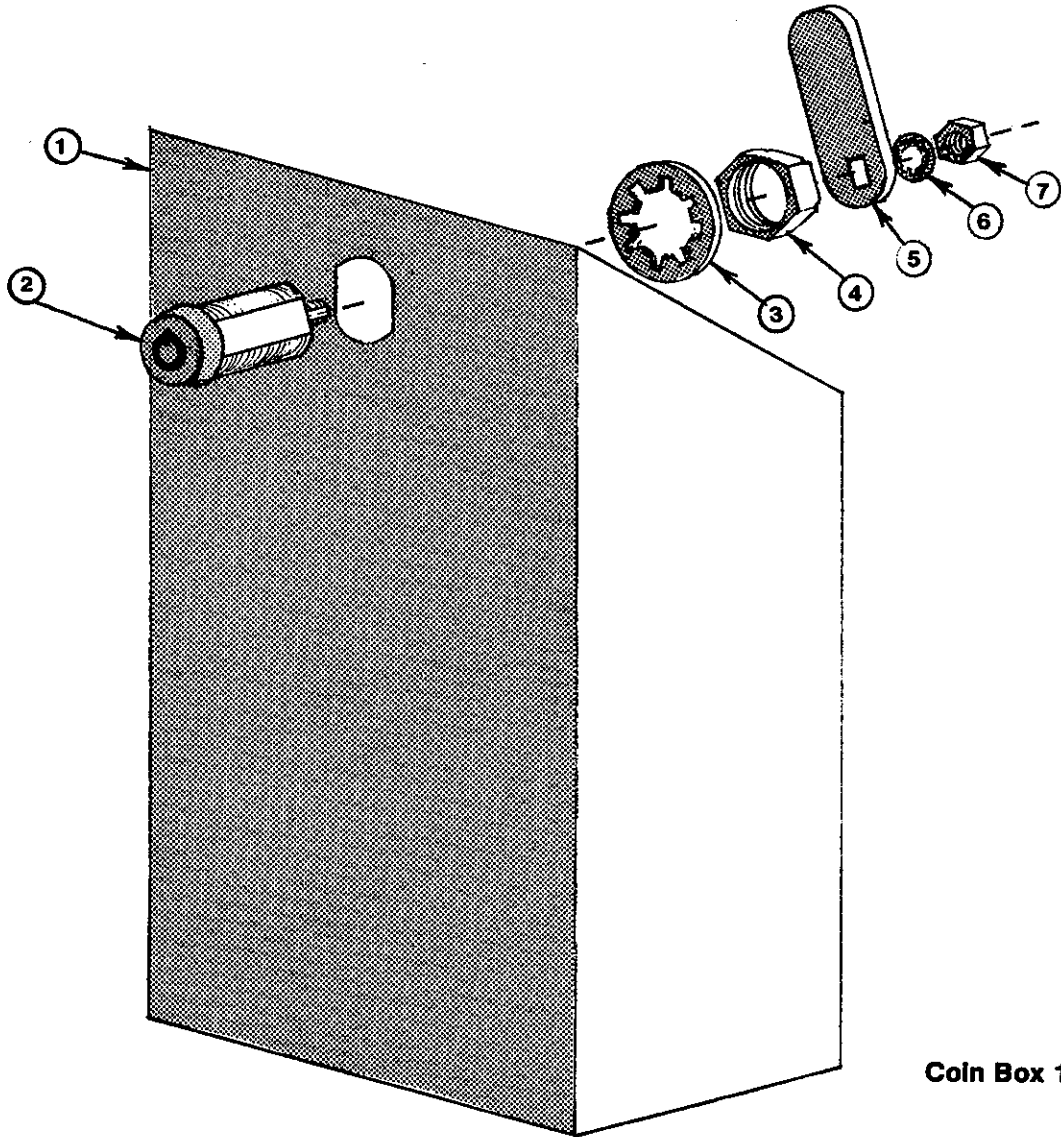

Coin Box 10665-01

Lock Assembly 11186

ITEM	PART NO.	DESCRIPTION
1	10665-01	Coin Box
2	351*	Tumbler
3	366	Lockwasher Int. Tooth 3/4"
4	1788	Hex Nut, 9/32" thick x 3/4" - 27
5	5404	Straight Cam
6	357	Lockwasher, Shakeproof 9/32"
7	358	Hex Nut 5/32" thick x 9/32" - 28

* Please specify key number when ordering. Lock is keyed -02 unless otherwise specified on order. Other keys available are -27 thru -48.

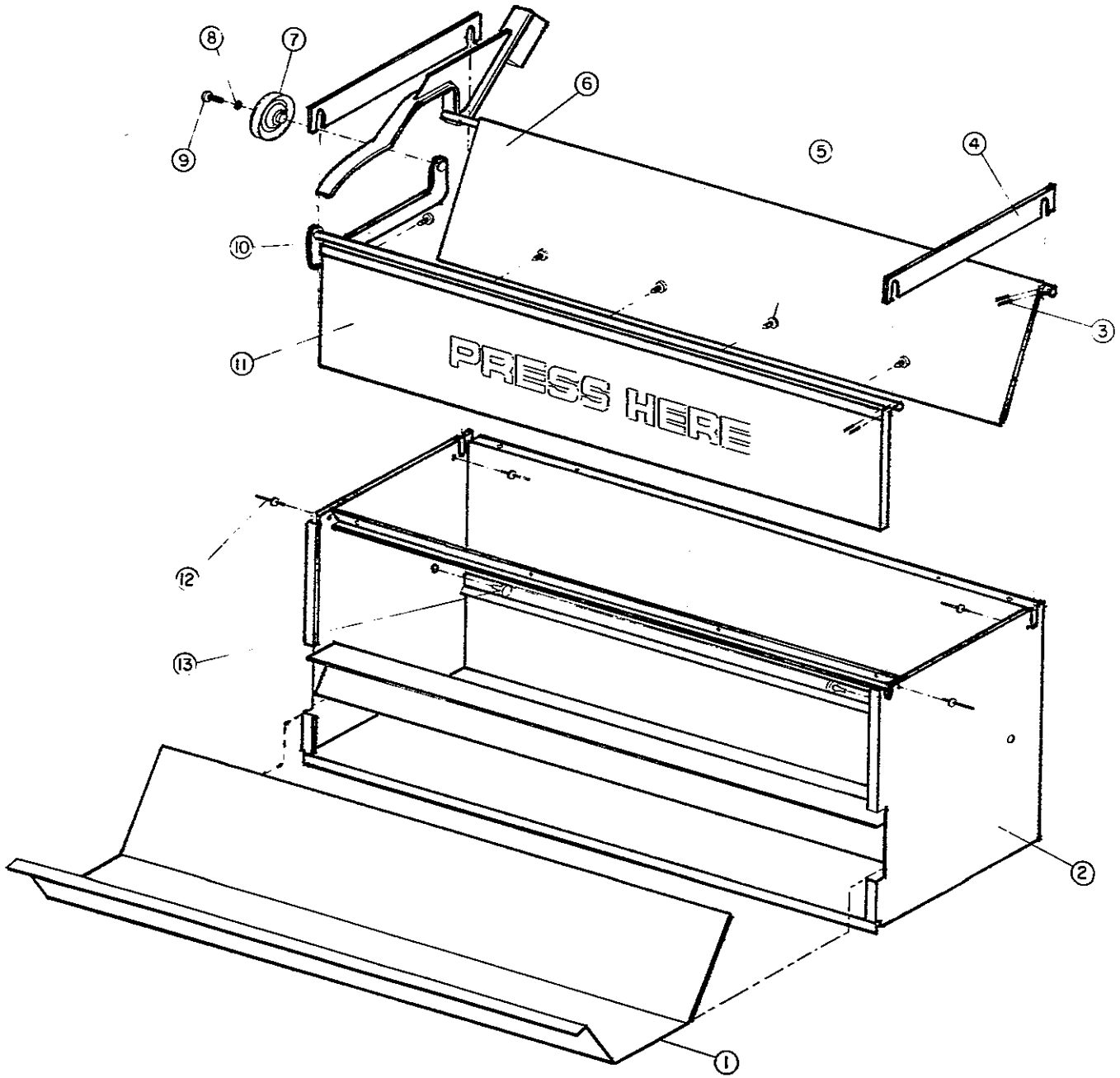

DELIVERY COMPARTMENT ASSEMBLY COMPLETE 10668

ITEM	PART NUMBER	DESCRIPTION
1	1394	Bottom - False
2	10662-01	Compartment W.A. - Delivery
3	1272	Pin - Roll 3/32" x 5/8"
4	1401	Retainer - Del. Comp. Door
5	1298	Screw - TP "AB" Pan #8
6	10315-01	Door W.A. - Anti-theft
7	534	Wheel - Roller Skate
8	266	Washer - Int. Tooth #8
9	681	Screw - TP "F" Pan #8
10	10335-01	Arm W. A. - Channel
11	1419-01	Door - Plexiglass
12	729	Rivet - "Pop" .125 dia. x .232
13	842	Bumper - Snap In, Rubber

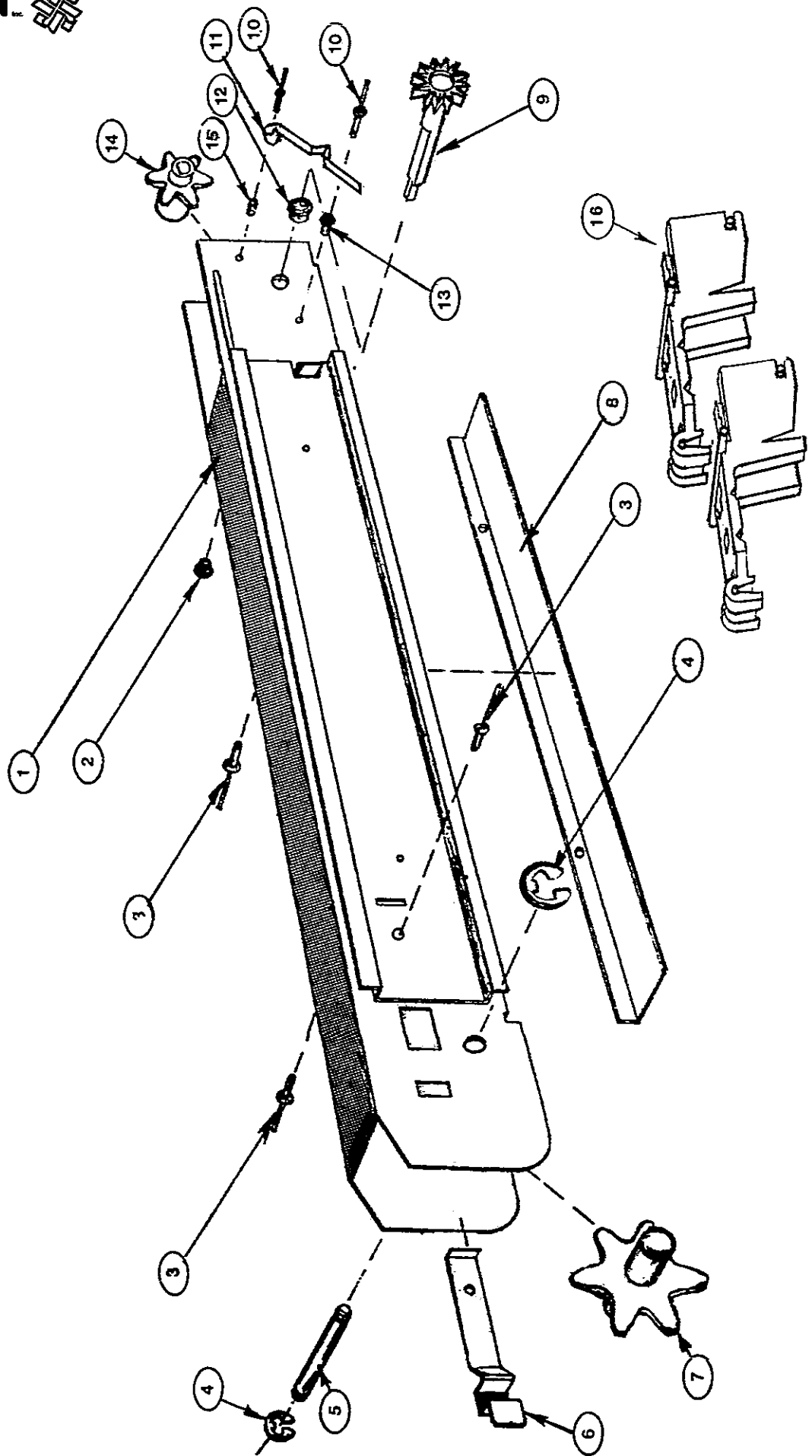

RACK MODULE - 13065-01

ITEM	PART NO.	DESCRIPTION
1	10895	Slide & Module Assembly
2	13512	Bearing - Flanged
3	729	"Pop" Rivet SD-42-BS
4	2559	"E" Ring, Tru Arc
5	2558	Front Sprocket Shaft
6	1744	Spring Lock
7	2565	Sprocket - Front
8	1774	Chain Guide
9	12846	Gear Shaft
10	1642	"Pop" Rivet SD-45-BS
11	12810	Spring Detent
12	1178	Bearing Bushing
13	1745	Spacer - Detent, Spring "T"
14	2563	Sprocket - Rear
15	1869	Spacer - Detent, Spring "Plain"
16	10487	Chain Asy., Complete - Wedge

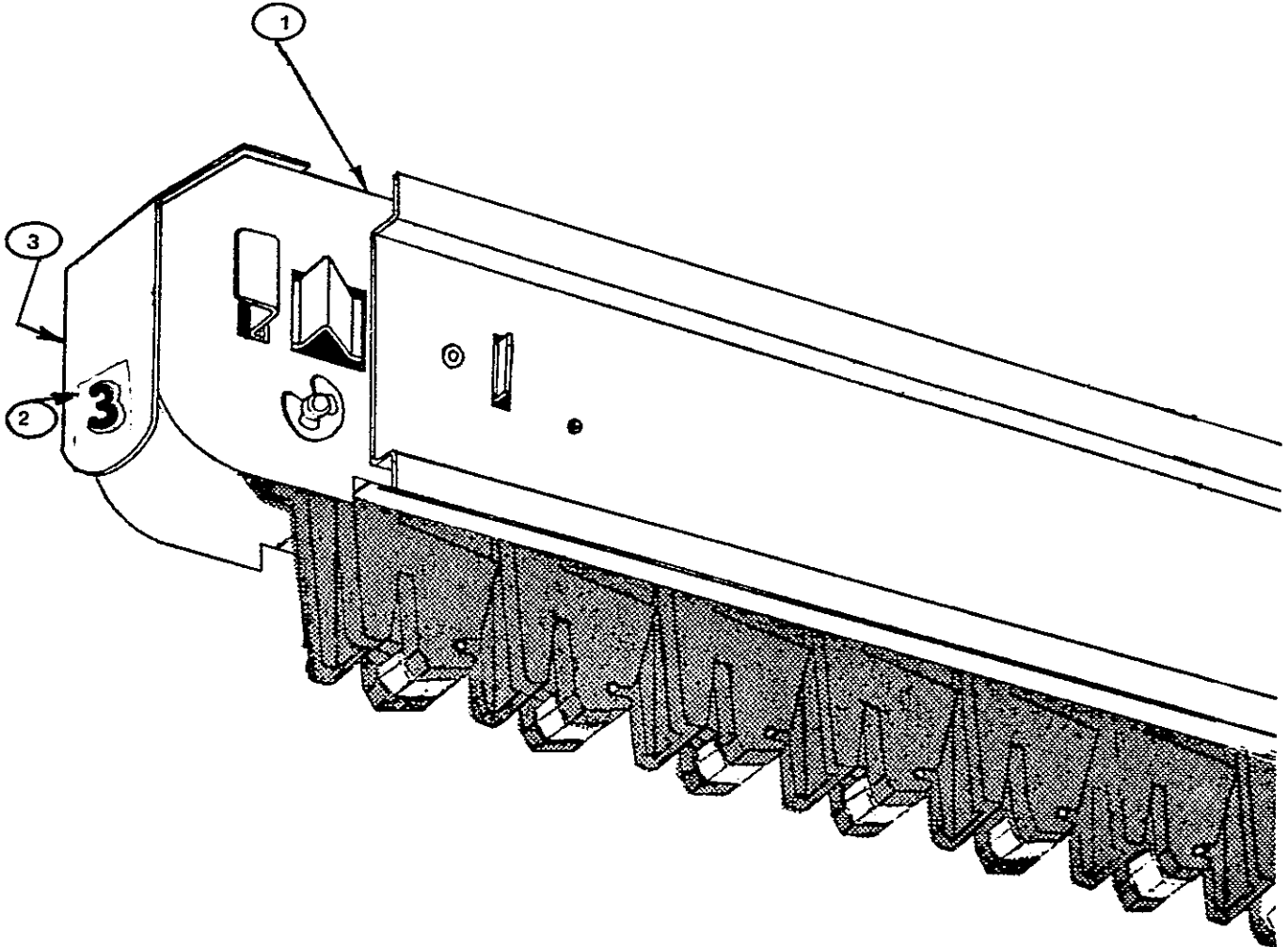

RACK MODULE ASSEMBLY

ITEM	PART NUMBER	DESCRIPTION
1	13065-01	Rack Module Assembly
2	1790	Decals - Selection Number 1-22
	1790-01	Decals - Selection Number 23-30
3	12287-01	Tab and Stripper Assembly - Plastic

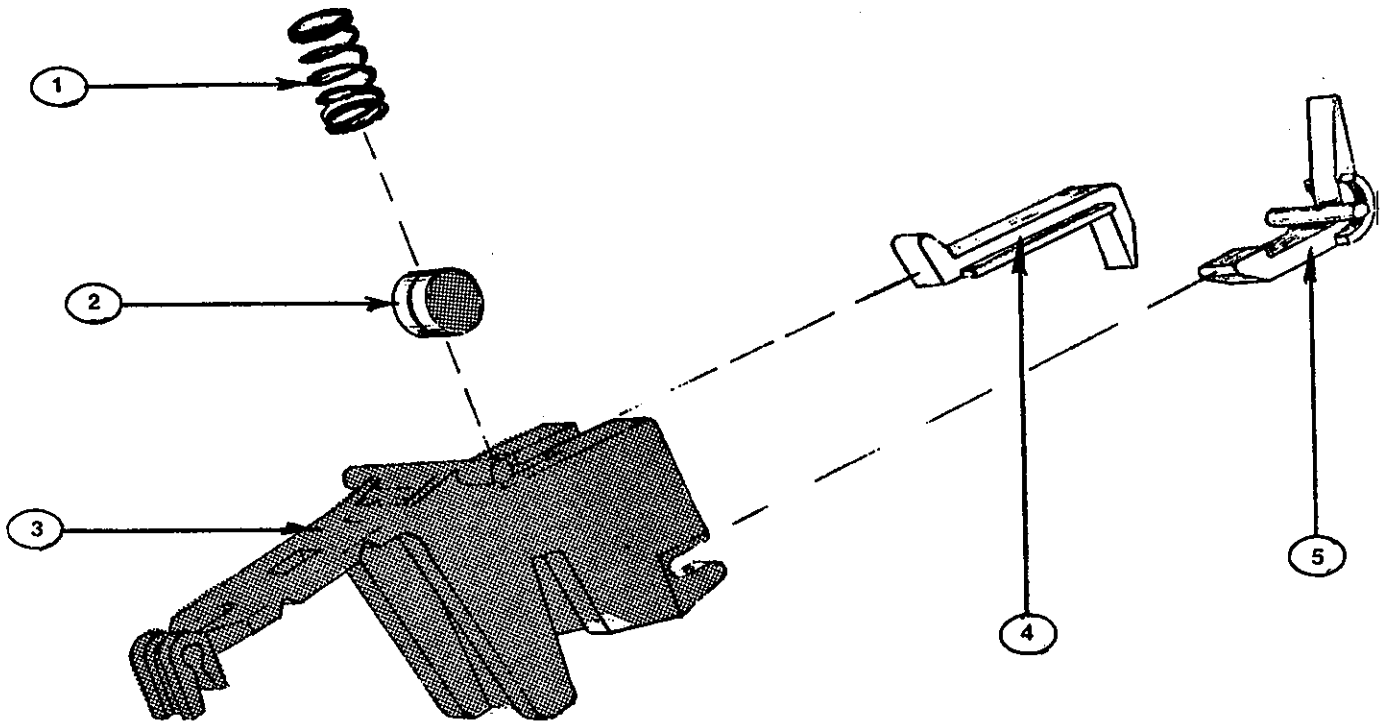

CHAIN SEGMENT ASSEMBLY A-10416

ITEM	PART NO.	DESCRIPTION
1	A-1720	Spring, Compression
2	A-1754	Wedge, Cylindrical (2 req)
3	D-1723	Chain Housing Segment
4	C-1717	Slide
5	C-1719	Lifter, Cylinder

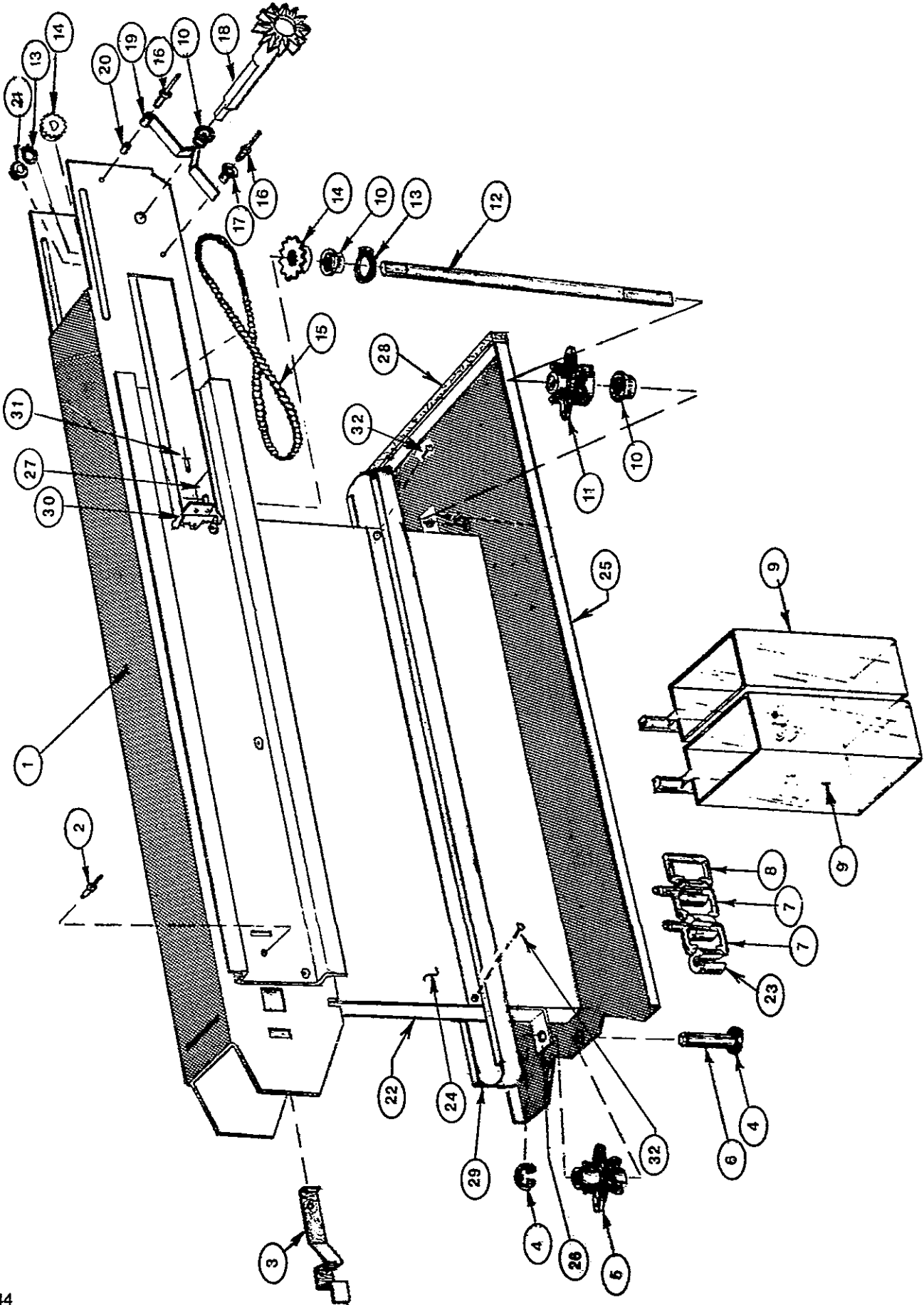

CANDY MODULE

ITEM	PART NO.	DESCRIPTION
1	10478-01	Candy Slide and Module
2	729	"Pop" Rivet SD-42-BS
3	1744	Spring Lock
4	2559	"E" Ring, Tru Arc
5	2565	Front Sprocket
6	2558	Front Sprocket Shaft
7	1945	Cup Retainer Link
8	1946	Plain Link
9	4886	Dispensing Cup
10	1178	Bearing Bushing
11	2563	Rear Sprocket
12	1939	Vertical Shaft
13	2225	Gripring
14	1927	Drive Sprocket
15	1928-01	Ladder Chain
16	1642	"Pop" Rivet AD-45-BS
17	1745	Spacer - Detent Spring "(T)"
18	12846	Gear - Shaft
19	12810	Spring - Detent
20	1869	Spacer - Detent Spring (Plain)
21	13512	Bearing - Flanged;
22	2321-01	Divider Left Side
23	10526	Chain Asy - Complete
24	2320-01	Divider - Right Side
25	4893	Bottom - Candy Module
26	1935-01	Retainer - Front Shaft
27	1936-01	Retainer - Rear Shaft
28	810-01	Stripping - Neoprene
29	12823	Guide - Cup Chain
30	4846	Plate - Rivet Reinforcement
31	4948	Rivet - Pop. 125D x .294
32	1298	Screw - T "AB" #8

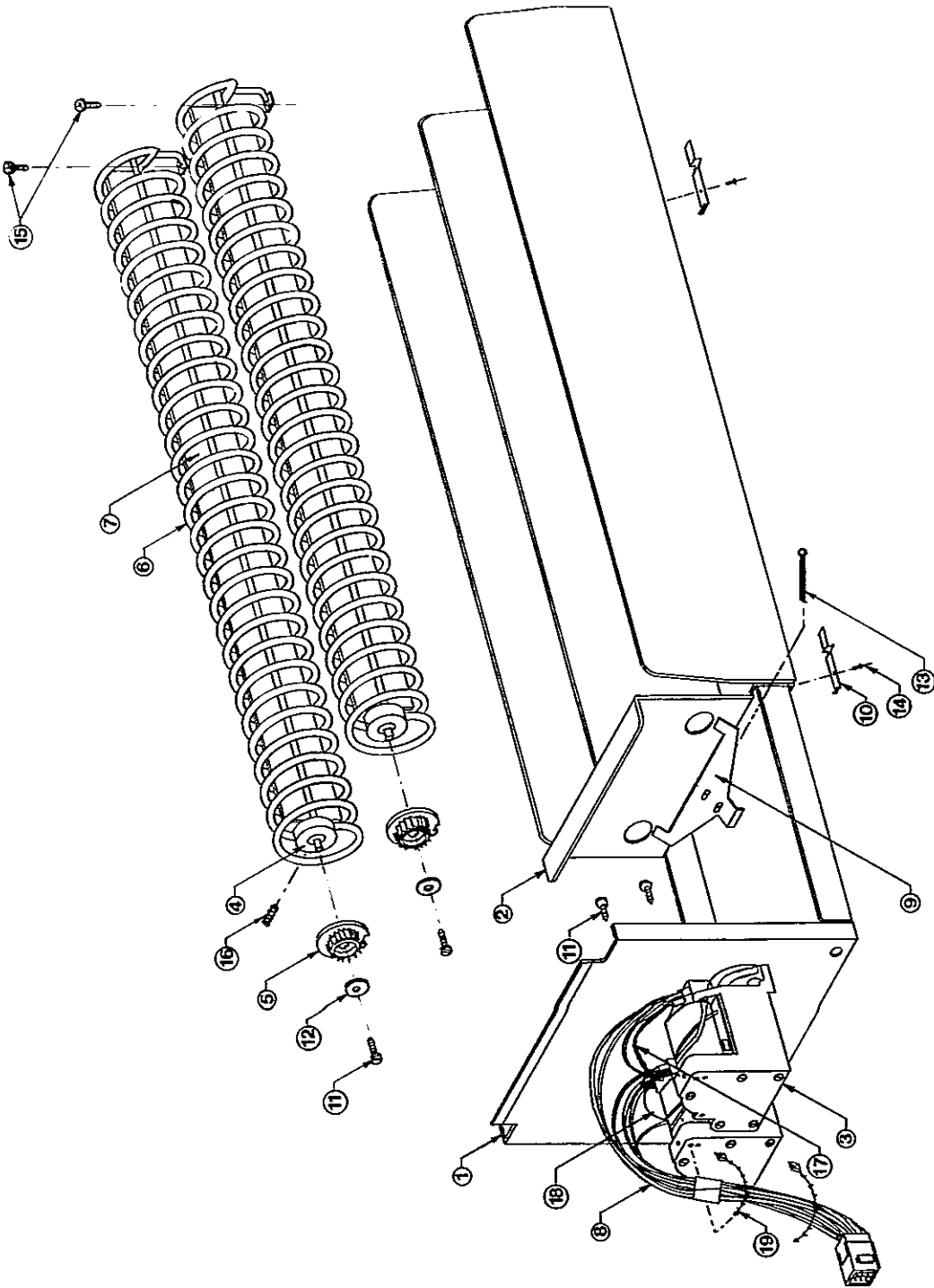

HELIX MODULE ASSEMBLY

HELIX MODULE ASSEMBLY

ITEM	PART NUMBER	DESCRIPTION
1	13061-01	Base W/A
2	12933-01	Tray W/A-Sliding
3	12816-02	180° Motor - Asy. Counterclockwise Rotation
	12816-01	180° Motor - Asy. Clockwise Rotation
	12817-02	360° Motor - Asy. Counterclockwise Rotation
4	12848	Bushing-Helix Drive
5	12849	Bear-W/Detent
6	13433	Helix-R.H. Gum & Mint
7	12913-01	Divider-W/A Gum & Mint
8	12836	Harness-Motor
9	13105-01	Latch Sub Asy-Detent
10	12813	Spring-Lock
11	12852	Screw-TP 4-20x $\frac{3}{8}$
12	4201	Washer-#6 Flat
13	12815	Pin-Cotter
14	729	Rivet-Pop
15	1868	Screw
16	13482	Screw-Set 6-32x $\frac{3}{8}$
17	12842	Jumper-Motor Harness
18	12843	Jumper-Motor Harness
19	1362	Ty-Wrap
	13433-01	Helix-L.H. Gum & Mint
	13431-01	Helix-L.H. 1 Inch-Small Candy
	13432-01	Helix-R.H. 1 Inch-Small Candy
	13431-02	Helix-L.H. 1 $\frac{3}{8}$ Inch-Medium Candy
	13432-02	Helix-R.H. 1 $\frac{3}{8}$ Inch-Medium Candy
	13431-03	Helix-L.H. 2 Inch-Large Bag/Pastry
	13432-03	Helix-R.H. 2 Inch-Large Bag/Pastry

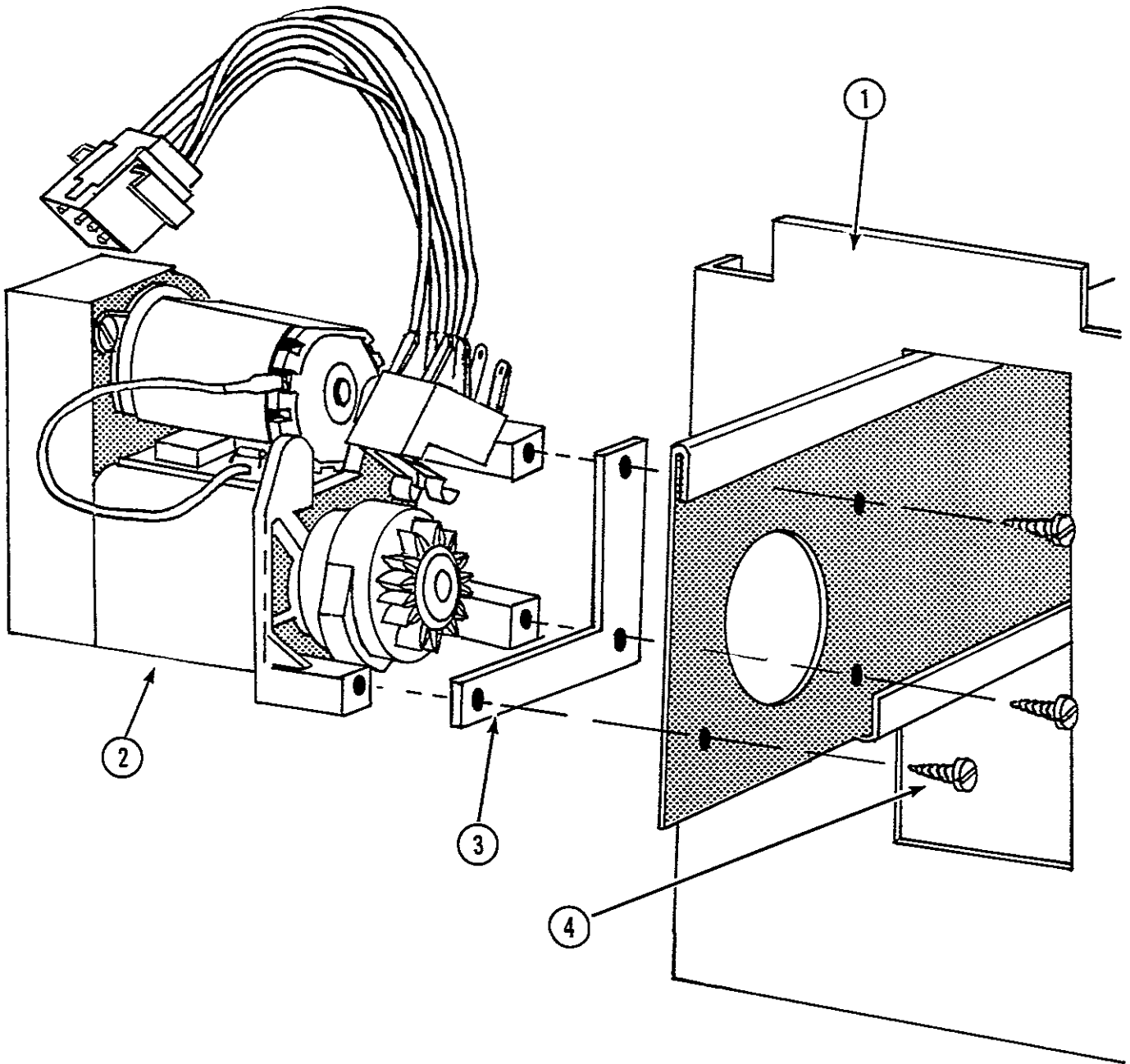

ITEM	PART NUMBER	DESCRIPTION
1	13059-01	Arm Asy - Wedge Module
2	12816-01	Motor Asy. 180° - Wedge
3	13624	Spacer - Motor
4	12852	Screw - 4 - 20 x 3/8

MOTOR ASSEMBLY

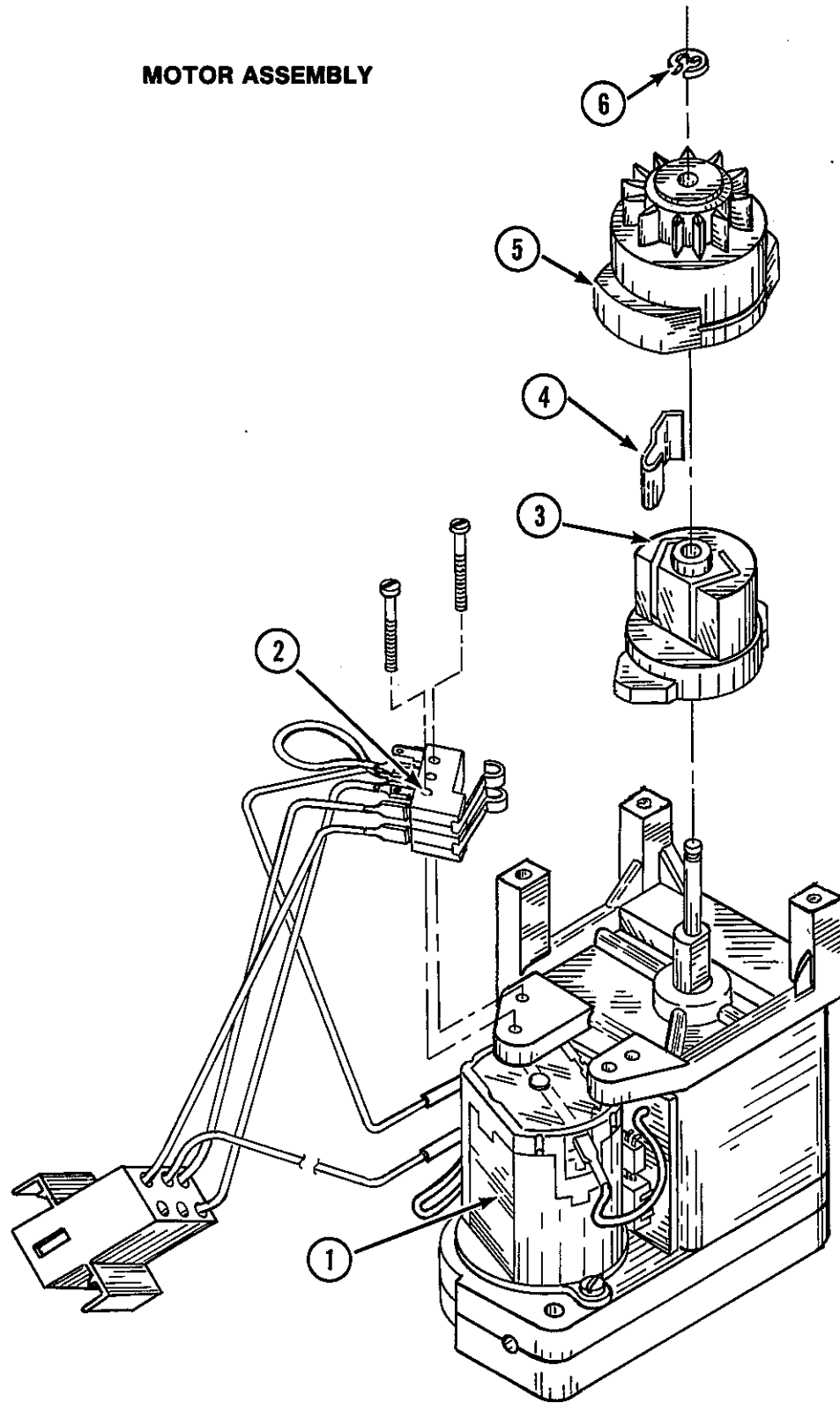

ALPHABETICAL PARTS LIST

PART NUMBER	DESCRIPTION
11598	Angle-Service Door-Corner Frame
10335-01	Arm and Channel-Delivery Comp.
13059-02	Arm Assembly-Module 13059-01
10665-01	Bank-Coin
104	Ballast
344	Barrell Lock-Rear Door
12834	Board-30 Price Switch
3193	Board Assy - 4 Price Terminal w/harness
1652	Board Assy - 4 Price Terminal Only
1477-01	Bottom-Display
1394	Bottom-False Delivery Compt.
1416-01	Bracket-Reject Lev. Mtg.
842	Bumper-Delivery Compt.
326	Bumper-Right Hand Inner Panel
1178	Bushing-Bearing Module Arm
1322	Bushing-Inner Panel
730	Bushing-Module Arm Shaft
2438	Bushing-Service Cord
1435	Bushing-Shoulder
570	Cam-Lock Rear Door
1483	Cam-Lock Service Door
5404	Cam-Straight Coin Bank Lock
1380	Cap-Escutcheon End
4949	Casting-Coin Insert
10487	Chain-Assembly Wedge Complete
1928-01	Chain-Confectionery-Ladder
10526	Chain-Confectionery-Plastic
1754	Chain-Cylinder (2 Required)
1723	Chain-Housing
1719	Chain-Lifter
10416	Chain-Segment Complete
1717	Chain-Slide
1720	Chain-Spring
13135	Chute-Upper Coin
348	Clip-Lock Rear Door
10668	Compartment-Delivery

PART NUMBER	DESCRIPTION
1473	Cord-Service
8436-01	Cover-Wire
10342	Cup-Coin Return
4886	Cup-Confectionery
8571-02	Decal-15¢
8571-03	Decal-20¢
8571-04	Decal-25¢
thru-18	Decal-95¢
1790	Decal-Selection Number 1-22
12844	Decal-Price Board
1790-01	Decal-Selection Number 23-30
1790	Decal-Serial Number
1479-01	Deflector-Left Hand
1439-01	Deflector-Right Hand
10356-01	Door-Rear
3887	Door-Service
13068-01	Door-Sliding
12766	Equalizer-Leg
13063	Escutcheon
10340-01	Fixture Assy-Lamp
11596	Frame-Service Door Hinge Side
11594	Frame-Service Door Lock Side
11595	Frame-Service Door Top or Bottom
1488	Fuse-24V-3.2 AMP
1487	Fuse Holder-24V
11600	Gasket-Service Door
1924	Glass-Service Door
12666	Harness-Correct Change
12677	Harness-Indicator Light
13675	Harness-Jones Plug 4 Price
12840	Harness-Jones Plug Multi Price
1629	Harness-Lamp Side
1520	Harness-Lamp Top
13679	Harness-Main Motor 4 Price
12841	Harness-Main Motor Multi Price
13678	Harness-Sub Main 4 Price
12838	Harness-Sub Main Multi Price
11597	Hinge-Service Door

PART NUMBER	DESCRIPTION
12814	Knob-Door
1616	Lamp-Correct Change
759	Lamp-Fluorescent
12766	Leg-Equalizer
10338-01	Leg and Plate Assy Block
13134-01	Lever-Reject
5262	Light Indicator
11537	Lock-T Handle
13793	Manual-Service
13121-01	Module-Confectionery
13070	Module-Helix Gum and Mint
13066-01	Module-Helix 1"
13066-02	Module-Helix 1 3/8"
13066-03	Module-Helix 2"
13069-03	Module-Pastry
13065-01	Module-Rack Chain
12816-01	Motor Asy. 180° (Wedge)
12817-02	Motor Asy. 360° (Helix)
347	Nut-Hex Rear Door
11538	Nut-Hex Service Door
12693	Panel-Power
12711-01	Panel-Right Hand Inner
1407	Pendulum-Sliding Door
1293-37	Plate Data
12819-01	Plate-Inst.
1302	Plate-Patent Notice
1484	Plate-Polyvend
13134-01	Reject Lever
729	Rivet-Pop
1414	Plate-Reject Cover
12669	Receptacle-Clip On
638	Screw-#8 Flat
1715	Screw-#8 Pan
11894	Screw-23 Pan # 8 Coin Insert Casting
1298	Screw-#8 3/8"
286	Screw-#10 Round



PART NUMBER	DESCRIPTION
1868	Screw-Module Arm
746	Screw-Service Door
11969	Spacer-Rear Door
89	Spring-Reject Lever
2607	Starter-FS 25
11539	Stop-Cam Service Door
1472	Stripping-Neoprene
11808	Support-Circuit Board
12839	Switch-Selector
12287-01	Tab and Stripper
12703-01	Track-Upper
1470-00	Trim-Delivery Compt. Side
1470-01	Trim-Delivery Compt. Top and Bottom
342-01	Tumbler-PD-20
1809-01	Tumbler-PO-1
345	Washers-Tab Lock Rear Door
1680	Washers-½ Service Door
5365	Wire-Ground 9"
1709	Wire-Ground 32"

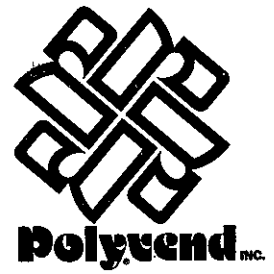

Polyend INC.

P. O. Box 1166
Conway, Ark. 72032 USA
Phone (501) 327-1301

Polyend INT., INC.

P. O. Box 1166
Conway, Ark. 72032 USA
Phone (501) 327-1301
Telex 536237 USA

Polyend LTD.

8 Jefferson Way
Thame, Oxon OX 93 UN England
Phone (084 421) 3454
Telex 837534